



US010714986B2

(12) **United States Patent**
Partovi

(10) **Patent No.:** **US 10,714,986 B2**
(45) **Date of Patent:** **Jul. 14, 2020**

(54) **INTELLIGENT INITIATION OF INDUCTIVE CHARGING PROCESS**

- (71) Applicant: **MOJO MOBILITY, INC.**, Santa Clara, CA (US)
- (72) Inventor: **Afshin Partovi**, Sunnyvale, CA (US)
- (73) Assignee: **Mojo Mobility, Inc.**, Santa Clara, CA (US)
- (*) Notice: Subject to any disclaimer, the term of this patent is extended or adjusted under 35 U.S.C. 154(b) by 232 days.

- (21) Appl. No.: **14/556,760**
- (22) Filed: **Dec. 1, 2014**

(65) **Prior Publication Data**
US 2015/0130412 A1 May 14, 2015

Related U.S. Application Data
(63) Continuation of application No. 13/708,838, filed on Dec. 7, 2012, now Pat. No. 8,901,881, which is a (Continued)

(51) **Int. Cl.**
H02J 7/02 (2016.01)
H02J 50/80 (2016.01)
(Continued)

(52) **U.S. Cl.**
CPC **H02J 50/80** (2016.02); **H01F 7/0252** (2013.01); **H02J 5/005** (2013.01); **H02J 50/12** (2016.02);
(Continued)

(58) **Field of Classification Search**
CPC H02J 7/025; H01F 38/14
(Continued)

(56) **References Cited**

U.S. PATENT DOCUMENTS

- 3,938,018 A 2/1976 Dahl
- 4,311,853 A 1/1982 Cree
- (Continued)

FOREIGN PATENT DOCUMENTS

- JP 2000341885 12/2000
- JP 2003045731 2/2003
- (Continued)

OTHER PUBLICATIONS

Japanese Patent Office, Examiner's Reconsideration Report for Japanese Patent Application No. 2010-507666, dated Jul. 17, 2014, 1 page.

(Continued)

Primary Examiner — Jerry D Robbins
(74) *Attorney, Agent, or Firm* — Louis Wu

(57) **ABSTRACT**

A system for intelligent initiation of an inductive charging process. In accordance with an embodiment, the system comprises a receiver coil or receiver associated with a mobile device, and provided as a separable or after-market accessory for use with the mobile device. When the mobile device is placed in proximity to a base unit having one or more charger coils, the charger coil is used to inductively generate a current in the receiver coil or receiver associated with the mobile device, to charge or power the mobile device. The base unit and mobile device communicate with each other prior to and/or during charging or powering to determine a protocol to be used to charge or power the mobile device.

20 Claims, 18 Drawing Sheets

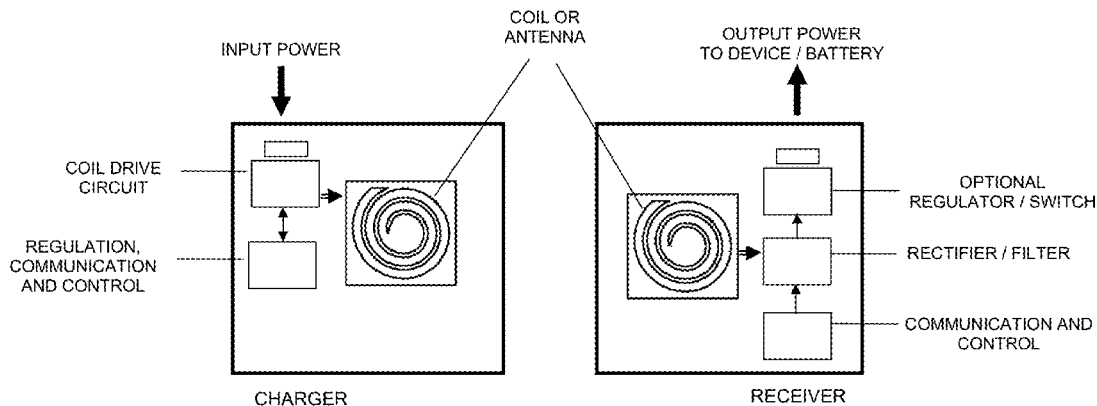

Related U.S. Application Data

- continuation of application No. 13/158,134, filed on Jun. 10, 2011, now Pat. No. 8,890,470.
- (60) Provisional application No. 61/354,114, filed on Jun. 11, 2010, provisional application No. 61/387,895, filed on Sep. 29, 2010, provisional application No. 61/478,015, filed on Apr. 21, 2011.
- (51) **Int. Cl.**
H02J 50/70 (2016.01)
H02J 50/90 (2016.01)
H02J 50/12 (2016.01)
H01F 7/02 (2006.01)
H02J 5/00 (2016.01)
H02J 7/00 (2006.01)
- (52) **U.S. Cl.**
 CPC *H02J 50/70* (2016.02); *H02J 50/90* (2016.02); *H01F 7/0247* (2013.01); *H02J 7/0044* (2013.01)
- (58) **Field of Classification Search**
 USPC 320/108
 See application file for complete search history.

References Cited

U.S. PATENT DOCUMENTS

4,311,953 A 1/1982 Fukuda
 4,415,959 A 11/1983 Vinciarelli
 4,731,585 A 3/1988 Fox
 4,800,328 A * 1/1989 Bolger B60L 5/005
 191/10
 4,873,677 A 10/1989 Sakamoto
 5,237,257 A 8/1993 Johnson
 5,311,973 A 5/1994 Tseng
 5,367,242 A * 11/1994 Hulman G08B 3/1075
 320/108
 5,434,493 A 7/1995 Woody
 5,543,702 A 8/1996 Pfeiffer
 5,550,452 A 8/1996 Shirai
 5,600,225 A 2/1997 Goto
 5,642,087 A 6/1997 Crow
 5,656,917 A 8/1997 Theobald
 5,696,433 A 12/1997 Patino
 5,734,254 A 3/1998 Stephens
 5,744,933 A 4/1998 Inoue
 5,889,384 A 5/1999 Hayes
 5,925,814 A 7/1999 Tsuzuki
 5,952,814 A 9/1999 Van Lerbergne
 5,959,433 A 9/1999 Rohde
 5,963,012 A 10/1999 Garcia
 5,991,170 A 11/1999 Nagai
 5,991,665 A 11/1999 Wang
 6,008,622 A 12/1999 Nakawatase
 6,016,046 A 1/2000 Kaito
 6,040,680 A 3/2000 Toya
 6,094,119 A 7/2000 Reznik
 6,184,651 B1 2/2001 Fernandez
 6,184,654 B1 2/2001 Bachner
 6,208,115 B1 3/2001 Binder
 6,301,128 B1 10/2001 Jang
 6,310,465 B2 10/2001 Najima
 6,331,744 B1 12/2001 Chen
 6,436,299 B1 8/2002 Baarman
 6,462,509 B1 10/2002 Abe
 6,489,745 B1 12/2002 Koreis
 6,498,455 B2 12/2002 Zink
 6,501,364 B1 12/2002 Hui
 6,573,817 B2 6/2003 Gottschalk
 6,586,909 B1 7/2003 Trepka
 6,625,477 B1 9/2003 Wakefield
 6,636,017 B2 10/2003 Zink
 6,650,088 B1 11/2003 Webb

6,673,250 B2 1/2004 Kuennen
 6,697,272 B2 2/2004 Nanbu
 6,731,071 B2 5/2004 Baarman
 6,741,064 B2 5/2004 Liu
 6,756,765 B2 6/2004 Bruning
 6,798,716 B1 9/2004 Charych
 6,803,744 B1 10/2004 Sabo
 6,803,774 B2 10/2004 Park
 6,806,649 B2 10/2004 Mollema
 6,812,645 B2 11/2004 Baarman
 6,825,620 B2 11/2004 Kuennen
 6,831,417 B2 12/2004 Baarman
 6,844,702 B2 1/2005 Giannopoulos
 6,870,089 B1 3/2005 Gray
 6,888,438 B2 5/2005 Hui
 6,906,495 B2 6/2005 Cheng
 6,913,477 B2 7/2005 Dayan
 6,917,163 B2 7/2005 Baarman
 6,917,182 B2 7/2005 Burton
 6,943,733 B2 9/2005 Vance
 6,972,543 B1 12/2005 Wells
 6,975,198 B2 12/2005 Baarman
 7,026,789 B2 4/2006 Bozzzone
 7,031,662 B2 4/2006 Suzuki
 7,042,196 B2 5/2006 Cheng
 7,116,200 B2 10/2006 Baarman
 7,118,240 B2 10/2006 Baarman
 7,126,450 B2 10/2006 Baarman
 7,132,918 B2 11/2006 Baarman
 7,151,357 B2 * 12/2006 Xian G06F 3/03543
 320/108
 7,162,264 B2 1/2007 Vance
 7,164,245 B1 1/2007 Chen
 7,164,255 B2 1/2007 Hui
 7,183,870 B2 2/2007 Takagi
 7,184,706 B2 2/2007 Someya
 7,209,084 B2 4/2007 Lindell
 7,211,986 B1 5/2007 Flowerdew
 7,221,919 B2 5/2007 Takagi
 7,239,110 B2 7/2007 Cheng
 7,248,017 B2 7/2007 Cheng
 7,305,258 B2 12/2007 Rydgren
 7,311,526 B2 12/2007 Rohrbach
 7,324,051 B2 1/2008 Hayes
 7,336,054 B2 2/2008 Crisp
 7,342,539 B2 3/2008 Rosenberg
 7,352,567 B2 4/2008 Hotelling
 7,355,150 B2 4/2008 Baarman
 7,376,408 B2 5/2008 Hayes
 7,378,817 B2 5/2008 Calhoon
 7,382,636 B2 6/2008 Baarman
 7,385,357 B2 6/2008 Kuennen
 7,388,543 B2 6/2008 Vance
 7,399,202 B2 7/2008 Dayan
 7,415,248 B2 8/2008 Andersson
 7,443,135 B2 10/2008 Cho
 7,462,951 B1 12/2008 Baarman
 7,477,195 B2 1/2009 Vance
 7,487,921 B2 2/2009 Takahashi
 7,495,414 B2 2/2009 Hui
 7,498,871 B2 3/2009 Ruuswik
 7,525,283 B2 4/2009 Cheng
 7,554,316 B2 * 6/2009 Stevens H02J 5/005
 307/104
 7,576,514 B2 8/2009 Hui
 7,605,496 B2 10/2009 Stevens
 D603,603 S 11/2009 Laine
 D607,879 S 1/2010 Ferber
 7,645,143 B2 1/2010 Rohrbach
 D611,407 S 3/2010 Webb
 D611,408 S 3/2010 Ferber
 7,733,215 B2 6/2010 Kozuma
 7,741,734 B2 6/2010 Joannopoulos
 7,781,916 B2 8/2010 Boys
 D624,316 S 9/2010 Ferber
 7,804,054 B2 9/2010 Shalom
 D625,721 S 10/2010 Ferber
 7,825,543 B2 11/2010 Karalis
 7,855,529 B2 12/2010 Liu

(56)	References Cited	2008/0272889	A1*	11/2008	Symons	H02J 7/025 340/10.1
	U.S. PATENT DOCUMENTS	2008/0278264	A1	11/2008	Karalis	
		2009/0015075	A1	1/2009	Cook	
	7,872,445	B2	1/2011	Hui	2009/0033564	A1 2/2009 Cook
	7,906,936	B2	3/2011	Azancot	2009/0043727	A1 2/2009 Cohen, Jr.
	7,915,858	B2*	3/2011	Liu	2009/0049554	A1 2/2009 Vuong
					2009/0058189	A1 3/2009 Cook
					2009/0058361	A1* 3/2009 John
	D636,333	S	4/2011	Kulikowski		A61N 1/3785 320/128
	7,948,208	B2	5/2011	Partovi	2009/0072627	A1 3/2009 Cook
	7,952,322	B2	5/2011	Partovi	2009/0072628	A1 3/2009 Cook
	D639,734	S	6/2011	Ferber	2009/0072629	A1 3/2009 Cook
	8,035,255	B2	10/2011	Kurs	2009/0079268	A1 3/2009 Cook
	8,040,103	B2	10/2011	Hui	2009/0096413	A1* 4/2009 Partovi
	8,049,370	B2	11/2011	Azancot		H01F 5/003 320/108
	8,050,068	B2	11/2011	Hussmann	2009/0102292	A1 4/2009 Cook
	8,069,100	B2	11/2011	Taylor et al.	2009/0127937	A1 5/2009 Widmer
	8,169,185	B2*	5/2012	Partovi	2009/0134712	A1 5/2009 Cook
					2009/0167449	A1 7/2009 Cook
	8,234,189	B2	7/2012	Taylor et al.	2009/0174263	A1 7/2009 Baamian et al.
	2002/0004167	A1	1/2002	Jenson	2009/0195332	A1 8/2009 Joannopoulos
	2002/0067238	A1	6/2002	Leu	2009/0195333	A1 8/2009 Joannopoulos
	2002/0089305	A1	7/2002	Park	2009/0212636	A1 8/2009 Cook
	2002/0093309	A1	7/2002	Peele	2009/0212637	A1 8/2009 Baamian et al.
	2003/0094921	A1	5/2003	Lau	2009/0212639	A1 8/2009 Johnson
	2003/0103039	A1	6/2003	Burr	2009/0213028	A1 8/2009 Cook
	2003/0210106	A1	11/2003	Cheng	2009/0224608	A1 9/2009 Cook
	2003/0214255	A1	11/2003	Baarman	2009/0224609	A1 9/2009 Cook
	2004/0113589	A1	6/2004	Crisp	2009/0224856	A1 9/2009 Karalis
	2004/0130915	A1	7/2004	Baarman	2009/0243397	A1 10/2009 Cook
	2004/0130916	A1	7/2004	Baarman	2009/0257259	A1 10/2009 Leibovitz
	2004/0145342	A1	7/2004	Lyon	2009/0267709	A1 10/2009 Joannopoulos
	2004/0145343	A1	7/2004	Naskali	2009/0267710	A1 10/2009 Joannopoulos
	2004/0150934	A1	8/2004	Baarman	2009/0284083	A1 11/2009 Karalis
	2004/0222751	A1	11/2004	Mollema	2009/0284227	A1 11/2009 Mohammadian
	2004/0232845	A1	11/2004	Baarman	2010/0007307	A1* 1/2010 Baarman
	2005/0007067	A1*	1/2005	Baarman		H02J 5/005 320/108
					2010/0038970	A1 2/2010 Cook
	2005/0017677	A1	1/2005	Burton	2010/0066176	A1 3/2010 Azancot
	2005/0063488	A1	3/2005	Troyk	2010/0070219	A1 3/2010 Azancot
	2005/0075696	A1	4/2005	Forsberg	2010/0072825	A1 3/2010 Azancot
	2005/0093475	A1	5/2005	Kuennen	2010/0073177	A1 3/2010 Azancot
	2005/0116650	A1	6/2005	Baarman	2010/0081473	A1 4/2010 Chatterjee
	2005/0116683	A1	6/2005	Cheng	2010/0096934	A1 4/2010 Joannopoulos
	2005/0122058	A1	6/2005	Baarman	2010/0102639	A1 4/2010 Joannopoulos
	2005/0122059	A1	6/2005	Baarman	2010/0102640	A1 4/2010 Joannopoulos
	2005/0127849	A1	6/2005	Baarman	2010/0102641	A1 4/2010 Joannopoulos
	2005/0127850	A1	6/2005	Baarman	2010/0109443	A1 5/2010 Cook
	2005/0127867	A1	6/2005	Calhoon	2010/0109445	A1 5/2010 Kurs
	2005/0127869	A1	6/2005	Calhoon	2010/0117454	A1 5/2010 Cook
	2005/0135122	A1	6/2005	Cheng	2010/0117455	A1 5/2010 Joannopoulos
	2005/0140482	A1	6/2005	Cheng	2010/0117456	A1 5/2010 Karalis
	2005/0162125	A1	7/2005	Yu	2010/0117596	A1 5/2010 Cook
	2005/0189910	A1	9/2005	Hui	2010/0123353	A1 5/2010 Joannopoulos
	2006/0021926	A1	2/2006	Woodard	2010/0123354	A1 5/2010 Joannopoulos
	2006/0038794	A1	2/2006	Schneidman	2010/0123355	A1 5/2010 Joannopoulos
	2006/0105718	A1	5/2006	Ozluturk	2010/0127573	A1 5/2010 Joannopoulos
	2006/0106965	A1	5/2006	Falcon	2010/0127574	A1 5/2010 Joannopoulos
	2006/0108977	A1	5/2006	Kagermeier	2010/0127575	A1 5/2010 Joannopoulos
	2006/0132045	A1	6/2006	Baarman	2010/0127660	A1* 5/2010 Cook
	2006/0146517	A1	7/2006	Park		H01Q 1/248 320/108
	2006/0202665	A1	9/2006	Hsu	2010/0133918	A1 6/2010 Joannopoulos
	2006/0205381	A1	9/2006	Beart	2010/0133919	A1 6/2010 Joannopoulos
	2006/0238930	A1	10/2006	Baarman	2010/0133920	A1 6/2010 Joannopoulos
	2006/0284593	A1	12/2006	Nagy	2010/0141042	A1 6/2010 Kesler
	2007/0029965	A1	2/2007	Hui	2010/0146308	A1* 6/2010 Gioscia
	2007/0069687	A1	3/2007	Suzuki		G06F 1/1632 713/300
	2007/0109708	A1	5/2007	Hussman	2010/0148589	A1 6/2010 Hamam
	2007/0139000	A1	6/2007	Kozuma	2010/0164296	A1 7/2010 Kurs
	2007/0178945	A1	8/2007	Cook	2010/0164297	A1 7/2010 Kurs
	2007/0182367	A1	8/2007	Partovi	2010/0164298	A1 7/2010 Karalis
	2007/0236174	A1	10/2007	Kaye	2010/0171368	A1 7/2010 Schatz
	2007/0279002	A1	12/2007	Partovi	2010/0171369	A1 7/2010 Taylor et al.
	2007/0296393	A1	12/2007	Malpas	2010/0181841	A1 7/2010 Azancot
	2008/0014897	A1	1/2008	Cook	2010/0181843	A1 7/2010 Schatz
	2008/0067874	A1	3/2008	Tseng	2010/0181845	A1 7/2010 Fiorello
	2008/0164839	A1	7/2008	Kato	2010/0184371	A1 7/2010 Cook
	2008/0247210	A1	10/2008	Hu	2010/0187911	A1 7/2010 Joannopoulos
	2008/0258679	A1	10/2008	Manico		

(56)

References Cited

FOREIGN PATENT DOCUMENTS

U.S. PATENT DOCUMENTS

2010/0190435 A1 7/2010 Cook
 2010/0190436 A1 7/2010 Cook
 2010/0194336 A1 8/2010 Azancot
 2010/0201313 A1 8/2010 Vorenkamp
 2010/0207572 A1 8/2010 Kirby
 2010/0207771 A1 8/2010 Trigiani
 2010/0213895 A1 8/2010 Keating
 2010/0219183 A1 9/2010 Azancot
 2010/0219693 A1 9/2010 Azancot
 2010/0219697 A1 9/2010 Azancot
 2010/0219698 A1 9/2010 Azancot
 2010/0235006 A1 9/2010 Brown
 2010/0244584 A1 9/2010 Azancot
 2010/0253281 A1 10/2010 Li
 2010/0253282 A1 10/2010 Azancot
 2010/0257382 A1 10/2010 Azancot
 2010/0259401 A1 10/2010 Azancot
 2010/0277120 A1 11/2010 Cook
 2010/0277121 A1* 11/2010 Hall B6L 11/182
 320/108
 2010/0314946 A1 12/2010 Budde
 2010/0327804 A1 12/2010 Takahashi
 2011/0012556 A1* 1/2011 Lai A63F 13/08
 320/108
 2011/0050164 A1 3/2011 Partovi
 2011/0057606 A1 3/2011 Saunamaki
 2011/0062793 A1 3/2011 Azancot
 2011/0090723 A1 4/2011 Hu
 2011/0095617 A1 4/2011 Cook
 2011/0115430 A1 5/2011 Saunamaki
 2011/0121660 A1 5/2011 Azancot
 2011/0157137 A1 6/2011 Ben-Shalom
 2011/0162035 A1 6/2011 King
 2011/0187318 A1 8/2011 Hui
 2011/0193520 A1 8/2011 Yamazaki
 2011/0217927 A1 9/2011 Ben-Shalom
 2011/0221387 A1 9/2011 Steigerwald
 2011/0221391 A1 9/2011 Won
 2011/0222493 A1 9/2011 Mangold
 2011/0266878 A9 11/2011 Cook
 2012/0041843 A1 2/2012 Taylor et al.
 2012/0049991 A1 3/2012 Baarman
 2012/0112552 A1 5/2012 Baarman et al.
 2012/0119588 A1 5/2012 Baarman et al.
 2012/0126745 A1 5/2012 Partovi
 2012/0146576 A1 6/2012 Partovi
 2012/0150670 A1 6/2012 Taylor et al.
 2012/0235636 A1 9/2012 Partovi
 2012/0259735 A1 10/2012 Taylor et al.
 2014/0339916 A1 11/2014 Fells et al.

JP 2006500894 1/2006
 JP 2006246633 9/2006
 JP 2009200174 9/2009
 KR 100836634 4/2008
 WO 20110156768 12/2011

OTHER PUBLICATIONS

The Patent Office of the People's Republic of China, 2nd Office Action for Chinese Patent Application No. 200880023854.4, dated Apr. 15, 2013, 4 pages.
 Unknown Author, System Description Wireless Power Transfer, vol. 1: Low Power Part 1: Interface Definition, Version 1.0, Jul. 2010, 83 pages.
 United States Patent and Trademark Office, Office Action for U.S. Appl. No. 13/829,346, dated Feb. 12, 2015, 10 pages.
 United States Patent and Trademark Office, Office Action for U.S. Appl. No. 13/829,186, dated Jan. 23, 2015, 12 pages.
 United States Patent and Trademark Office, Office Action for U.S. Appl. No. 13/828,933, dated Feb. 5, 2015, 11 pages.
 United States Patent and Trademark Office, Office Action for U.S. Appl. No. 13/352,096, dated Aug. 18, 2014, 14 pages.
 United States Patent and Trademark Office, Office Action for U.S. Appl. No. 13/708,584, dated Jan. 23, 2015, 25 pages.
 United States Patent and Trademark Office, Office Action for U.S. Appl. No. 12/769,586, dated Jun. 2, 2014, 23 pages.
 United States Patent and Trademark Office, Office Action for U.S. Appl. No. 13/708,520, dated Aug. 14, 2014, 9 pages.
 United States Patent and Trademark Office, Office Action for U.S. Appl. No. 13/115,811, dated Aug. 20, 2014, 20 pages.
 United States Patent and Trademark Office, Office Action for U.S. Appl. No. 14/135,082, dated Dec. 5, 2014, 14 pages.
 United States Patent and Trademark Office, Office Action for U.S. Appl. No. 13/708,520, dated Mar. 11, 2015, 10 pages.
 Office Action in connection with Japanese Application JP/2010-507666 (Japanese National Stage application of PCT/US2008/063084) dated Dec. 3, 2012, 4 pages.
 Office Action in connection with Chinese Application 200880023854.4 (Chinese National Stage application of PCT/US2008/063084) dated Aug. 28, 2012, 18 pages.
 European Search Report and Search Opinion in connection with Europe Application 08747863.2 (European National Stage application of PCT/US2008/063084) dated Apr. 2, 2013, 7 pages.
 International Search Report dated Jun. 14, 2013, International Application No. PCT/US2013/033352 filed Mar. 21, 2013, 3 pages.
 Japanese Patent Office, Office Action for Japanese Patent Application No. 2010-507666, dated Mar. 9, 2015, 8 pages.
 Japanese Patent Office, Office Action for Japanese Patent Application No. 2014-104181, dated Mar. 23, 2015, 14 pages.
 United States Patent Trademark Office, Office Action for U.S. Appl. No. 13/830,161, dated Apr. 16, 2015, 24 pages.

* cited by examiner

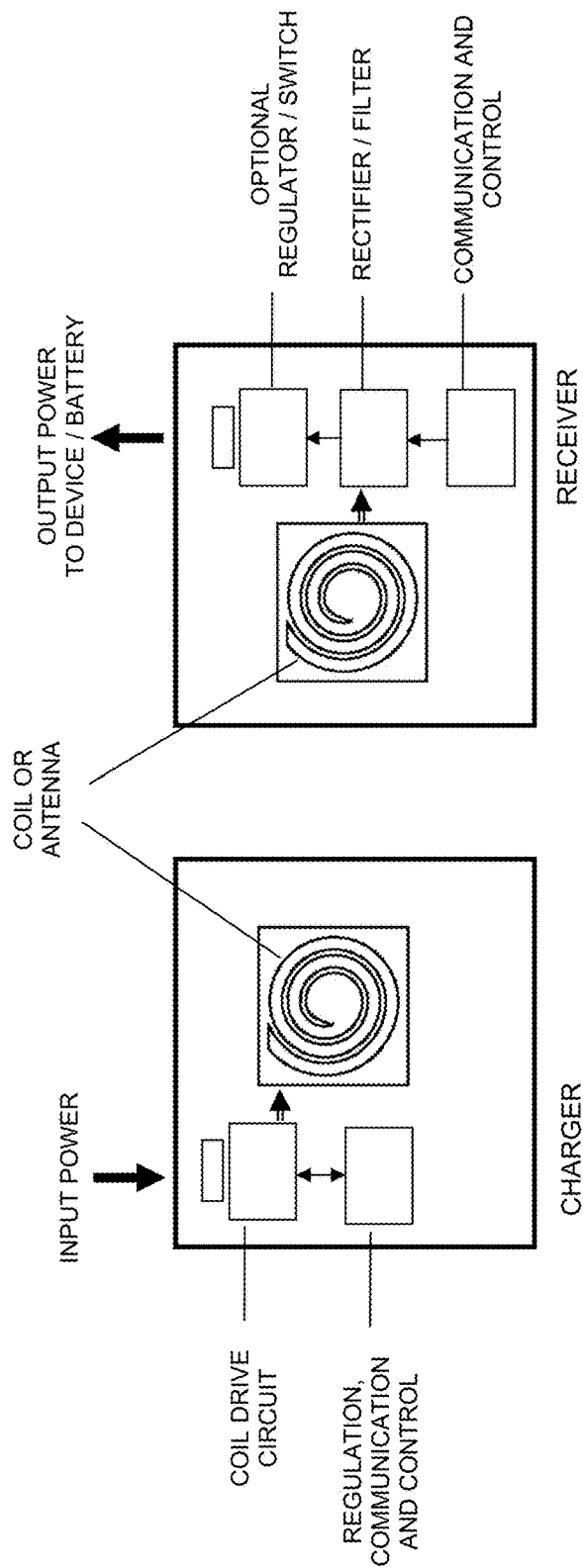

FIGURE 1

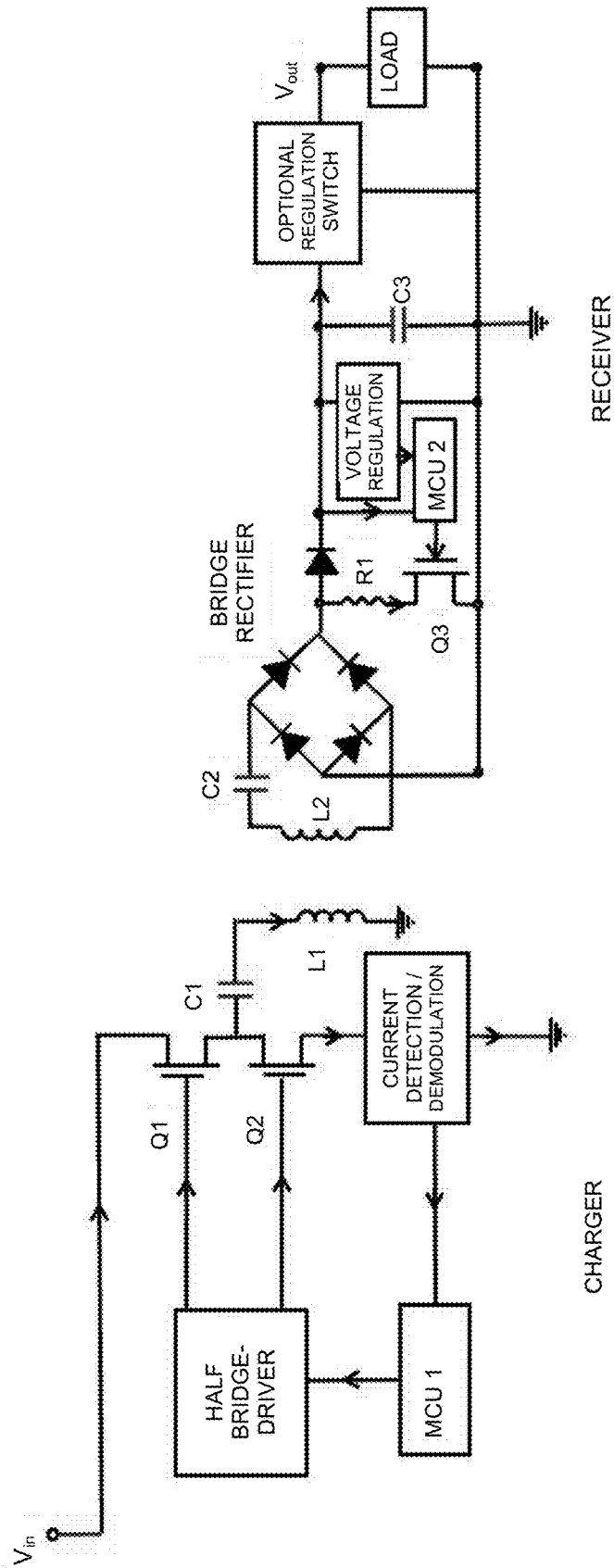

FIGURE 2

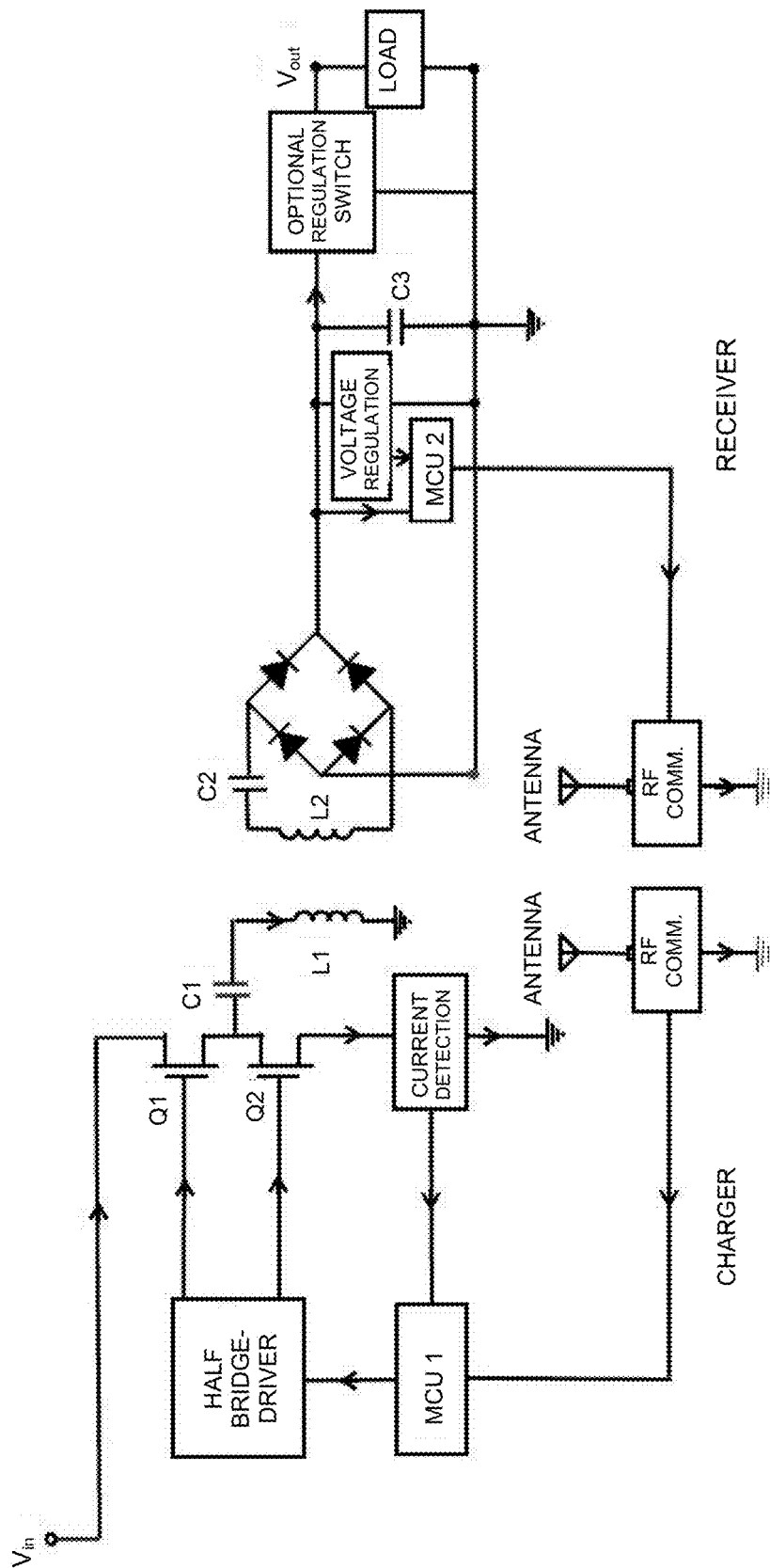

FIGURE 3

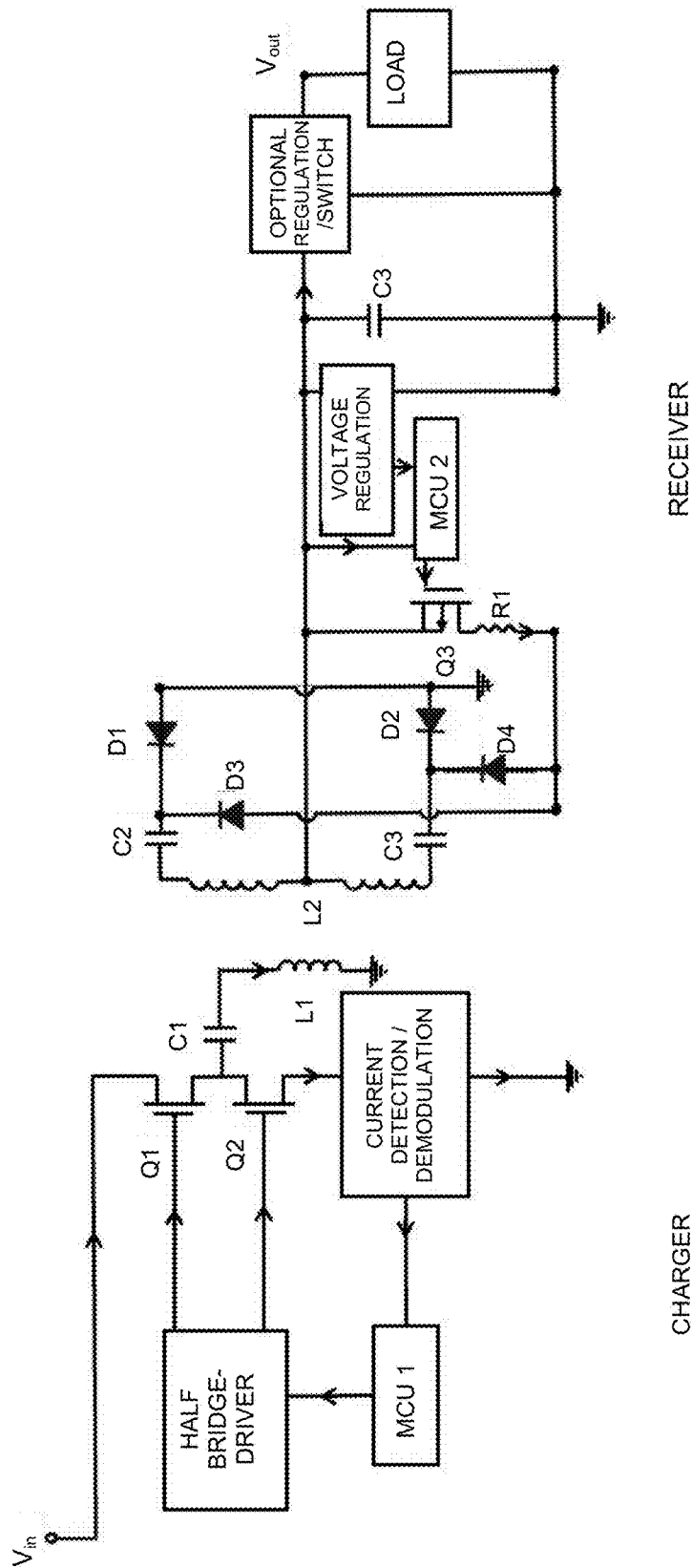

FIGURE 4

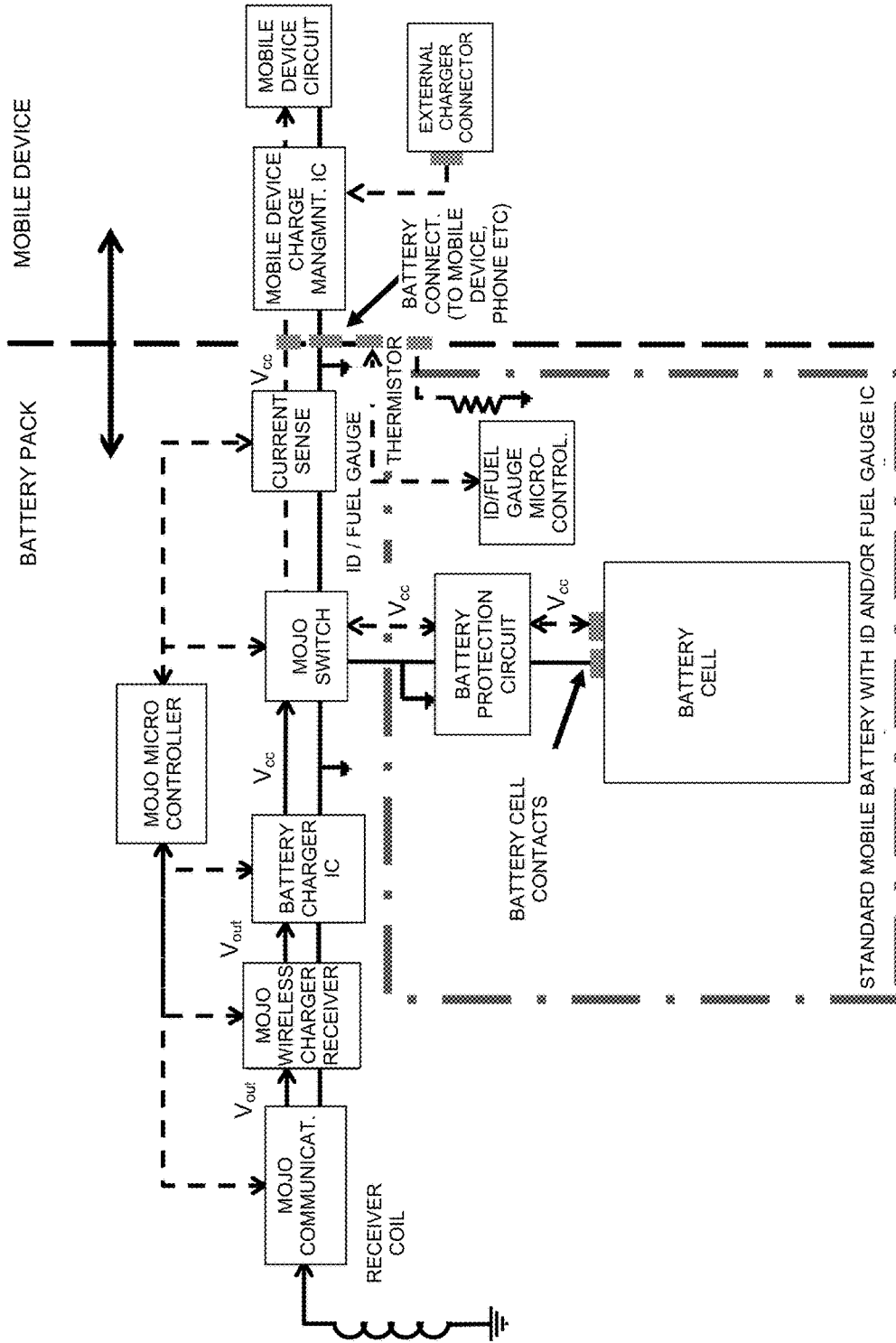

FIGURE 6

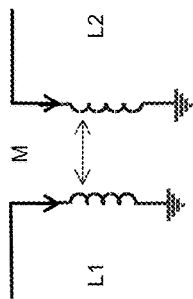

FIGURE 5

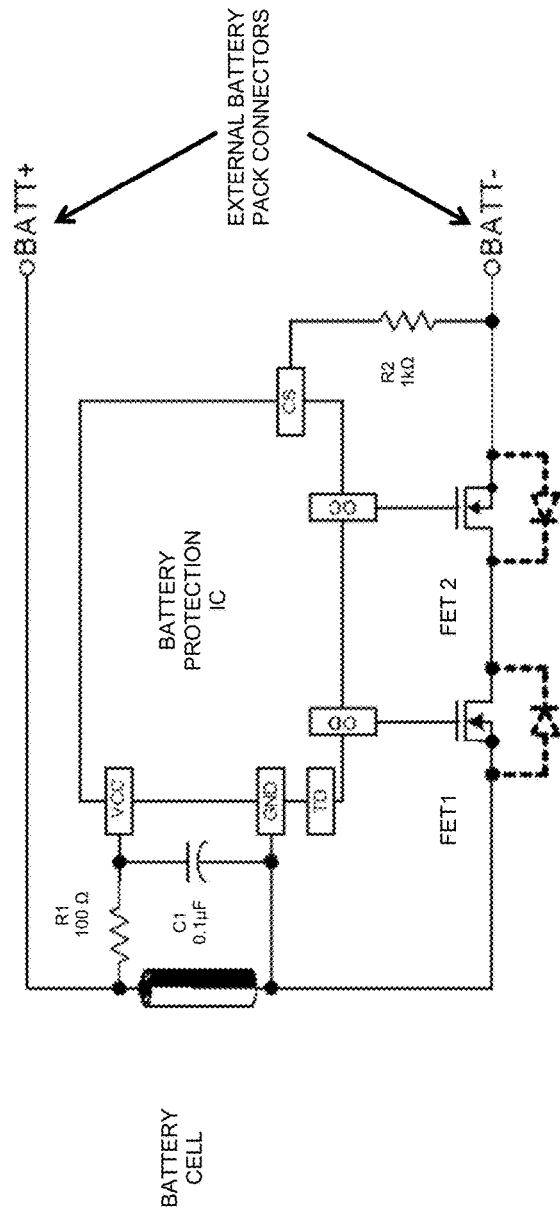

FIGURE 7

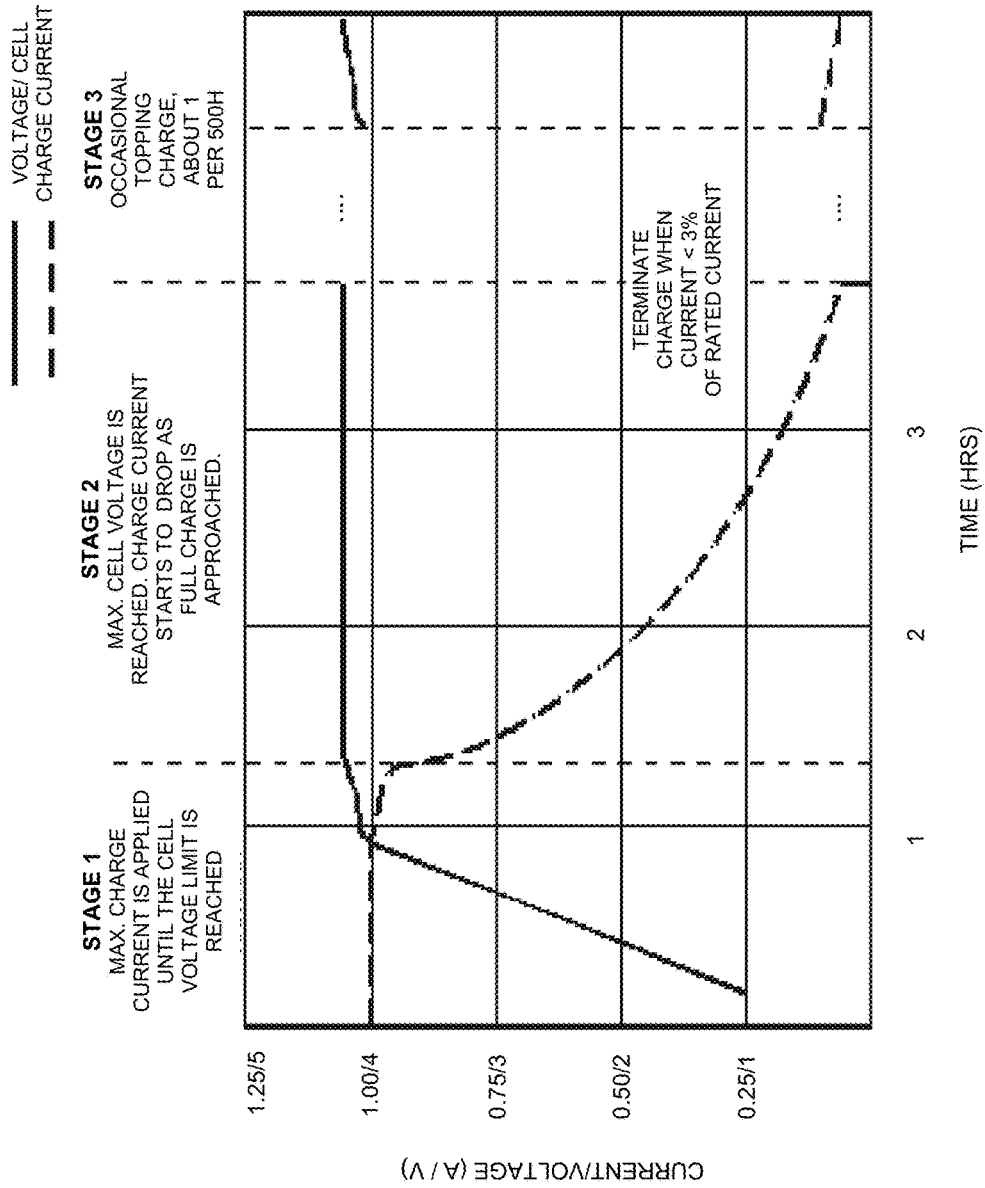

FIGURE 8

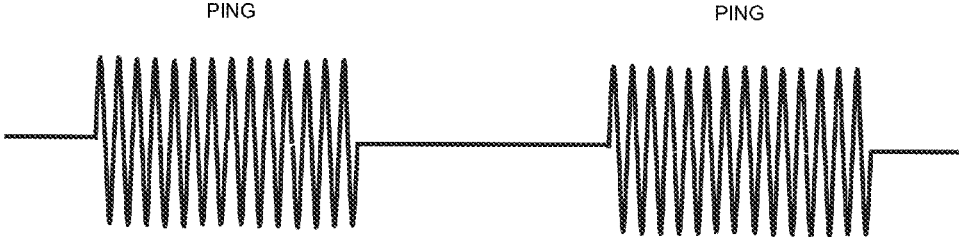

FIGURE 9

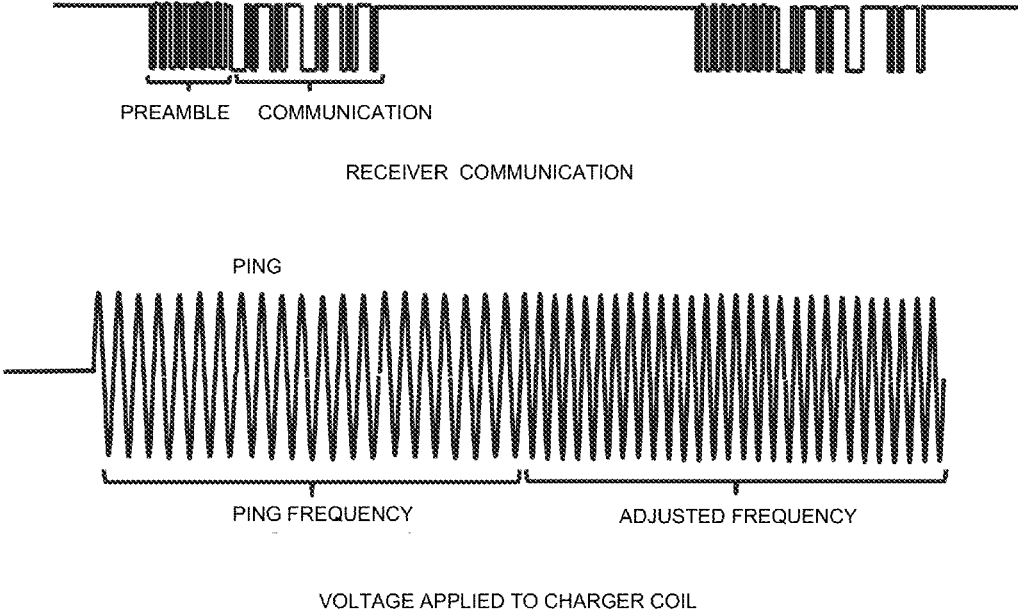

FIGURE 10

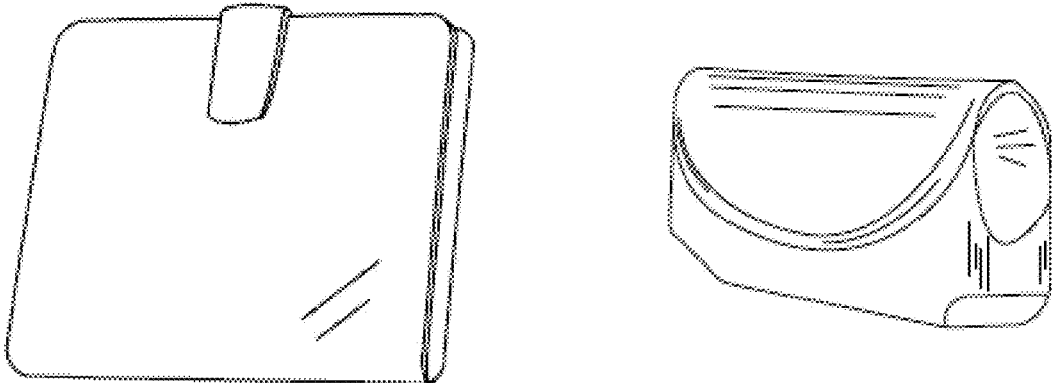

FIGURE 11

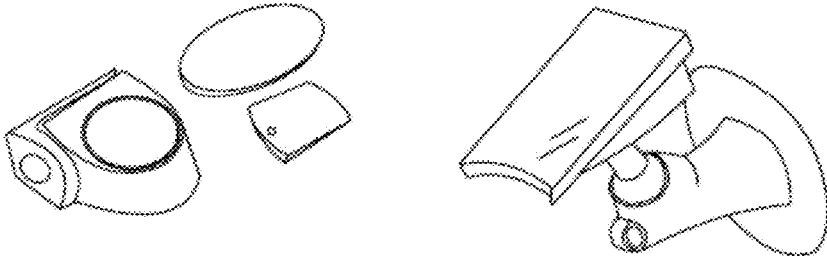

FIGURE 12

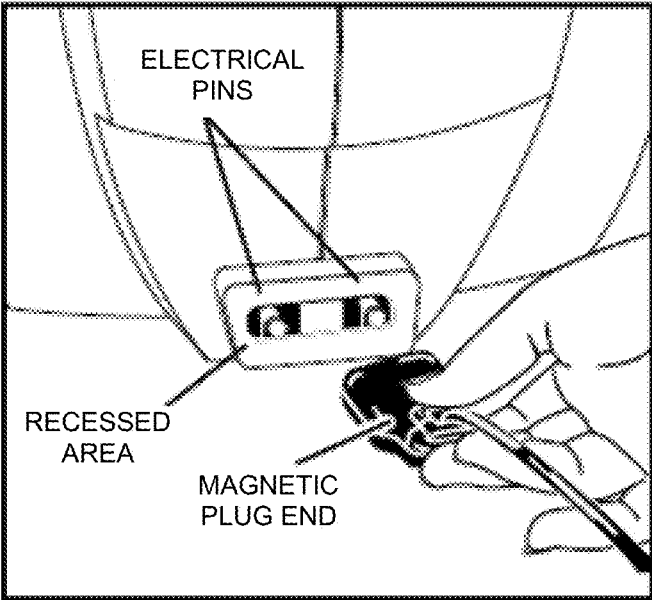
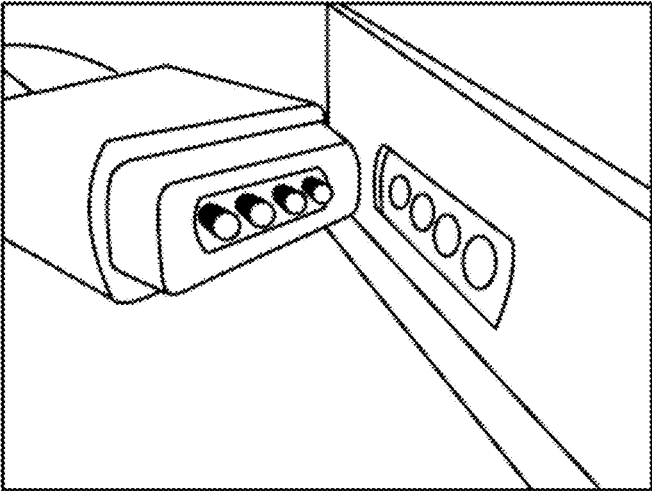

FIGURE 13

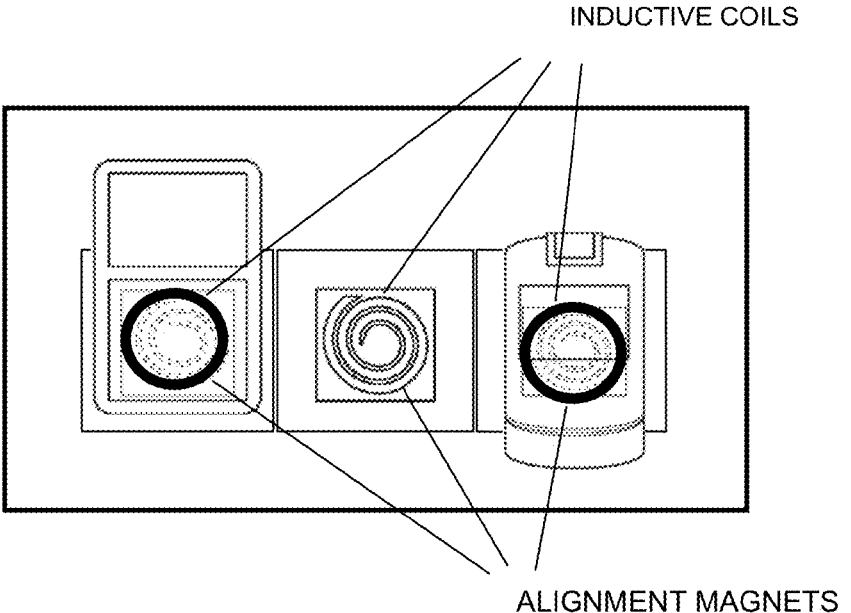
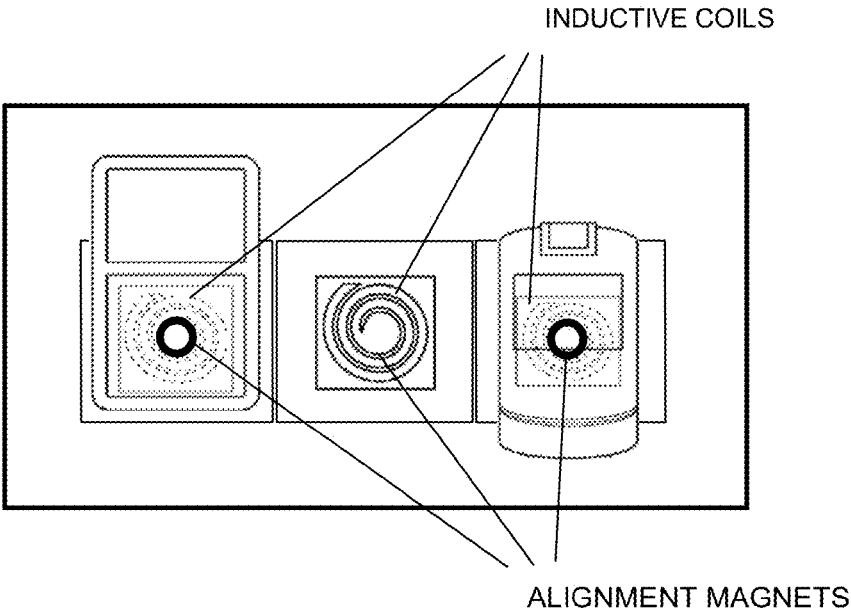

FIGURE 14

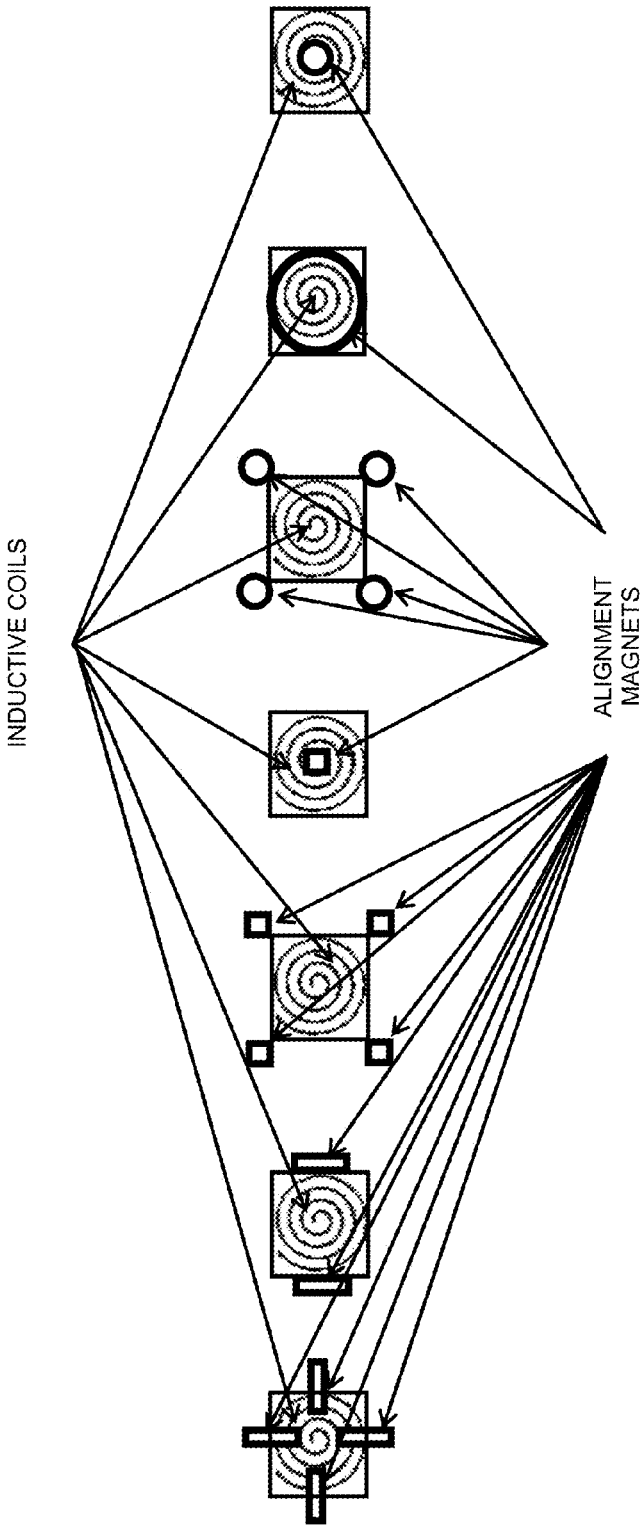

FIGURE 15

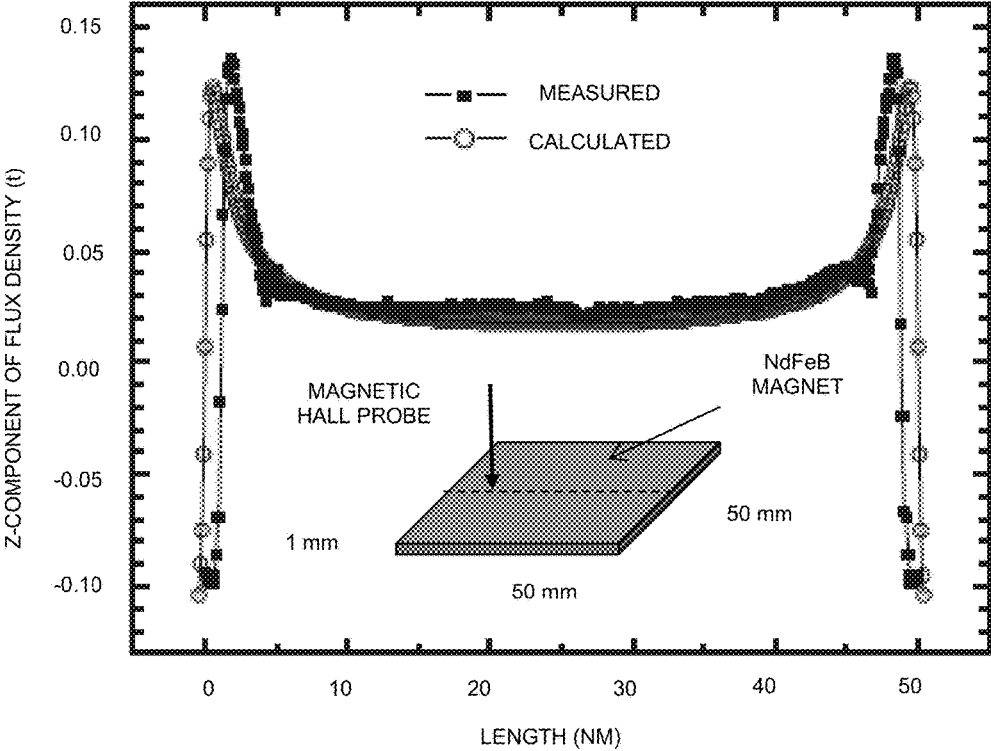

FIGURE 16

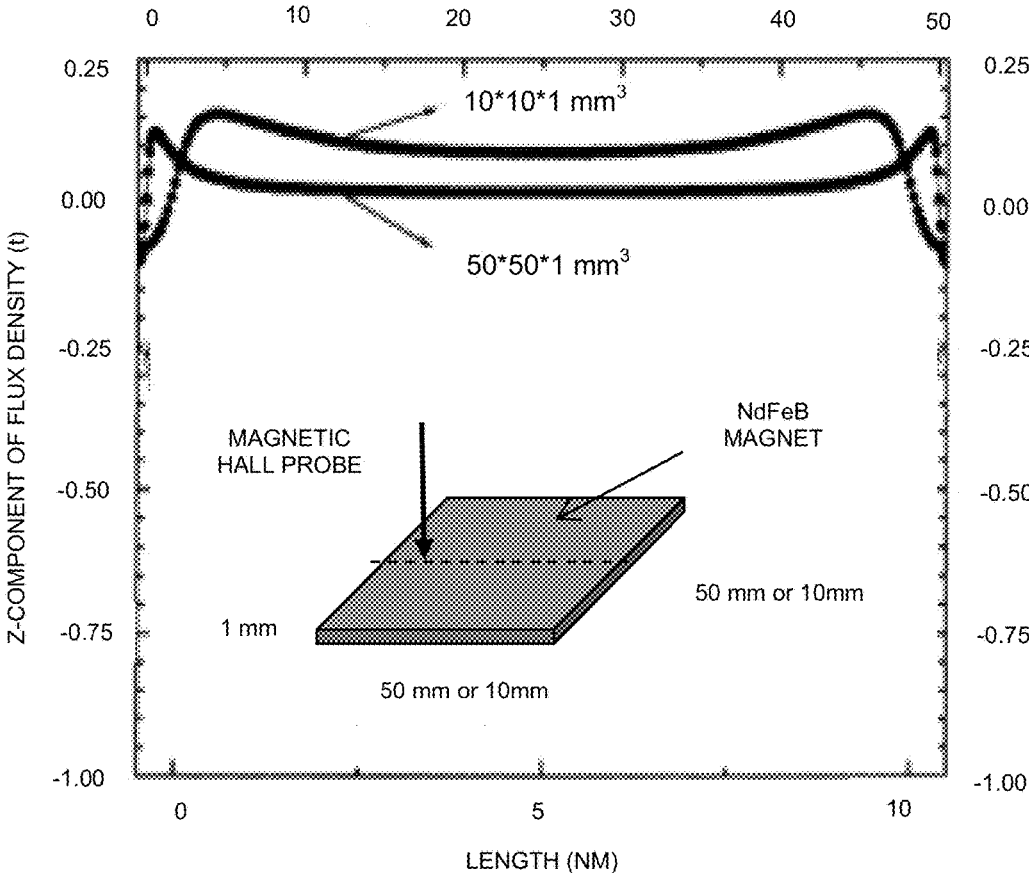

FIGURE 17

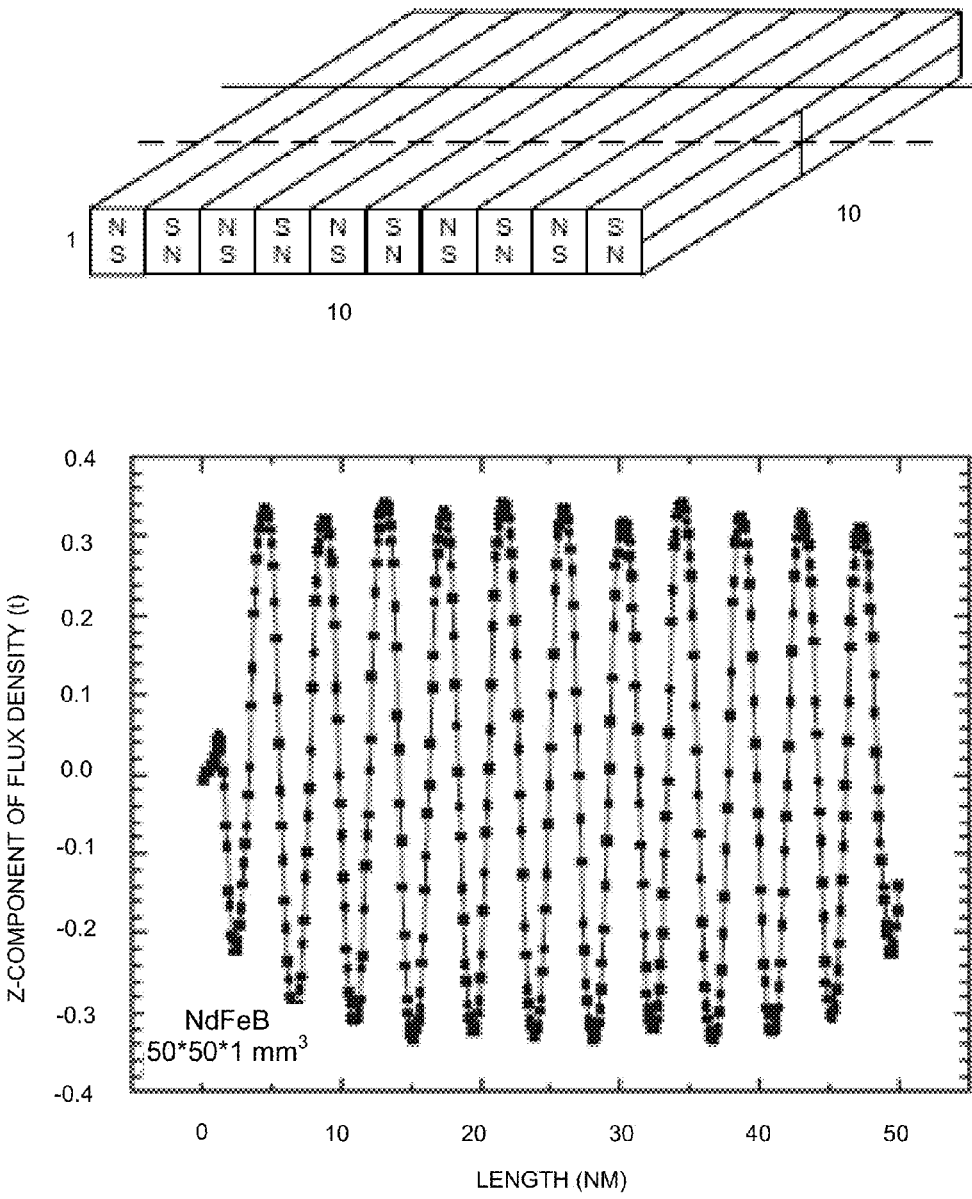

FIGURE 18

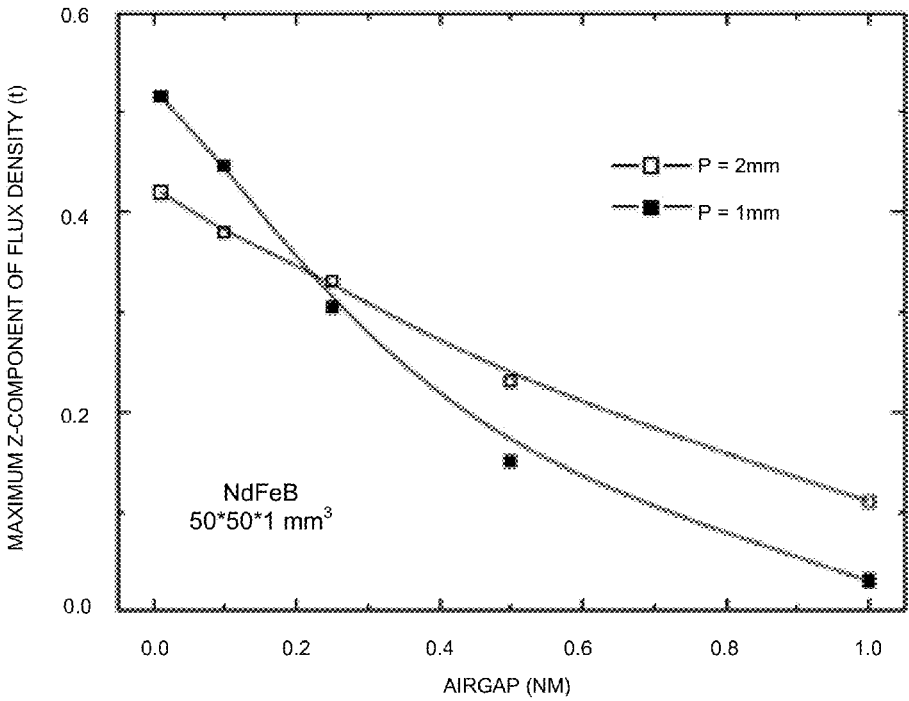
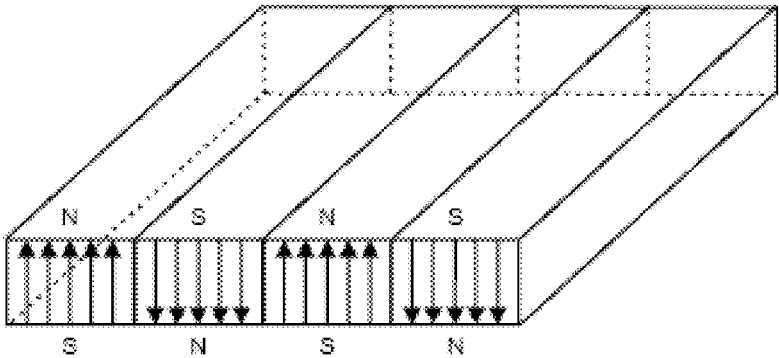
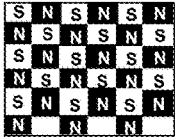

FIGURE 19



(a)



(b)



(c)



(d)

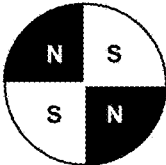

(e)

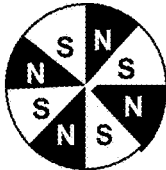

(f)

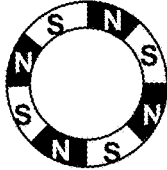

(g)



(h)

FIGURE 20

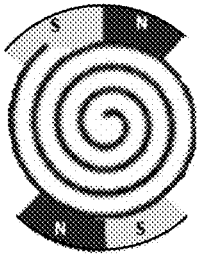
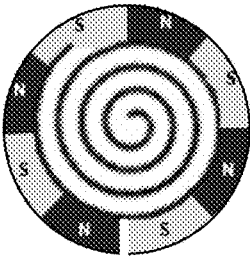

FIGURE 21

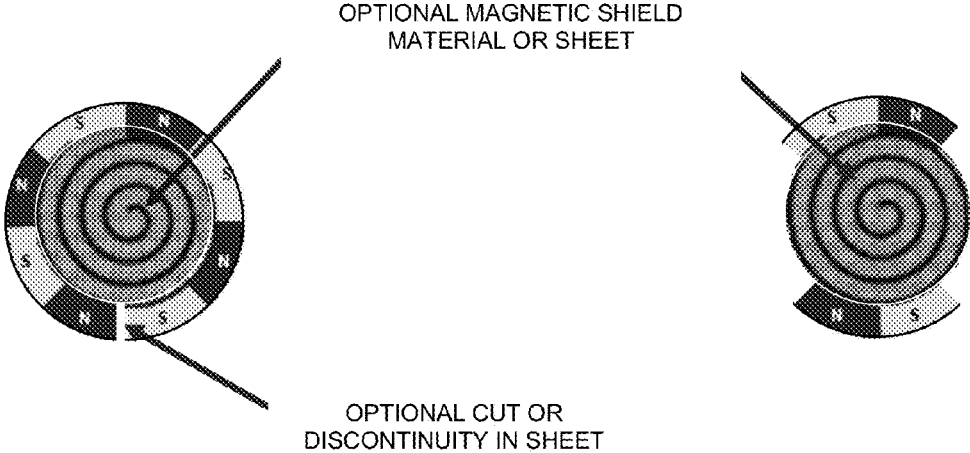

FIGURE 22

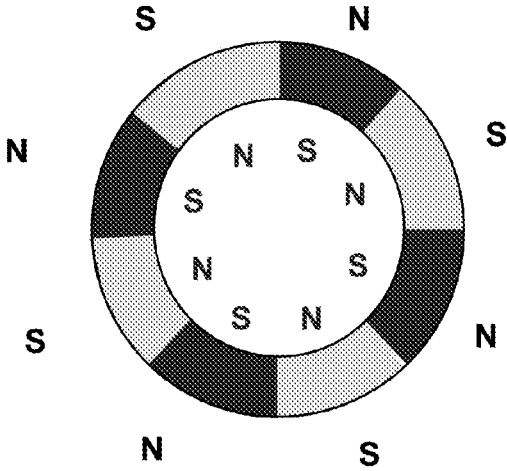

FIGURE 23

INTELLIGENT INITIATION OF INDUCTIVE CHARGING PROCESS

CLAIM OF PRIORITY AND CROSS-REFERENCE TO RELATED APPLICATIONS

This application is a continuation of U.S. patent application Ser. No. 13/708,838, titled "INTELLIGENT INITIATION OF INDUCTIVE CHARGING PROCESS", filed Dec. 7, 2012; which is a continuation of U.S. patent application Ser. No. 13/158,134, titled "SYSTEM FOR WIRELESS POWER TRANSFER THAT SUPPORTS INTEROPERABILITY, AND MULTI-POLE MAGNETS FOR USE THEREWITH", filed Jun. 10, 2011, and subsequently issued on Nov. 18, 2014 as U.S. Pat. No. 8,890,470; which application claims the benefit of priority to U.S. Provisional Patent Application No. 61/354,114, titled "IMPROVED MAGNETS FOR USE IN PROXIMITY TO MAGNETICALLY SENSITIVE PARTS OR DEVICES", filed Jun. 11, 2010; U.S. Provisional Patent Application No. 61/387,895, titled "SYSTEM AND METHOD FOR PROVIDING A UNIVERSAL-COMPATIBLE WIRELESS POWER SYSTEM", filed Sep. 29, 2010; and U.S. Provisional Patent Application No. 61/478,015, titled "SYSTEM AND METHOD FOR PROVIDING A UNIVERSAL-COMPATIBLE WIRELESS POWER SYSTEM", filed Apr. 21, 2011; which application is related to U.S. patent application Ser. No. 11/669,113, titled "INDUCTIVE POWER SOURCE AND CHARGING SYSTEM", filed Jan. 30, 2007; U.S. patent application Ser. No. 11/757,067, titled "POWER SOURCE, CHARGING SYSTEM, AND INDUCTIVE RECEIVER FOR MOBILE DEVICES", filed Jun. 1, 2007; U.S. patent application Ser. No. 12/116,876, titled "SYSTEM AND METHOD FOR INDUCTIVE CHARGING OF PORTABLE DEVICES", filed May 7, 2008; and U.S. patent application Ser. No. 12/769,586, titled "SYSTEM AND METHODS FOR INDUCTIVE CHARGING, AND IMPROVEMENTS AND USES THEREOF", filed Apr. 28, 2010; each of which above applications are herein incorporated by reference.

COPYRIGHT NOTICE

A portion of the disclosure of this patent document contains material which is subject to copyright protection. The copyright owner has no objection to the facsimile reproduction by anyone of the patent document or the patent disclosure, as it appears in the Patent and Trademark Office patent file or records, but otherwise reserves all copyright rights whatsoever.

FIELD OF INVENTION

The invention is generally related to inductive charging, including applications for use in mobile or other devices and vehicles, and improved compatibility and transfer of wireless power; and is also related to the use of magnets in electronic devices, and in particular to devices or parts having proximity to magnetic sensors.

BACKGROUND

Wireless technologies for powering and charging mobile and other electronic devices and vehicles have been developed. These systems generally use a wireless charger or transmitter system and a wireless receiver in combination to

provide a means for transfer of power across a distance. For safe and efficient operation the two parts of the system often communicate with each other to verify the presence of receivers and/or initiate charging and continued power transfer. To enable interoperability between chargers and receivers, it is important that the two parts of the system (the charger and the receiver) can communicate in a manner that allows such operation.

Additionally, many mobile, industrial, automotive, medical devices, etc. contain compasses or other components that are sensitive to magnetic field. At the same time, it is often desired to use magnets for fastening or attachment, or alignment purposes near such devices without affecting the operation of such sensitive material. One application may be fastening of a mobile device or phone to a surface in a car or other vehicle to avoid movement during transport.

These are the general areas that embodiments of the invention are intended to address.

SUMMARY

As described above, to enable interoperability between chargers and receivers, it is important that the two parts of the system (the charger and receiver) can communicate in a manner that allows operation. With the proliferation of different communication schemes, a multi-protocol system that can adapt and interoperate with different communication protocols allows maximum interoperability. Described herein are systems and methods for providing such multi-protocol operation and maximum interoperability. Also described herein are methods for use of magnets in or around magnetically sensitive devices such that the operation of such a device is not impaired. Applications in various devices and systems are described. In particular, applications for fastening mobile devices to their cases or other surfaces, and also alignment or attachment for power transfer or charging are described. Also described herein are systems and methods for the use of multi-pole and other magnets, in electronic and other articles, devices, components, or parts thereof.

BRIEF DESCRIPTION OF THE FIGURES

FIG. 1 illustrates an example of a wireless charger or power system that comprises a charger or transmitter part, and a receiver part, in accordance with an embodiment.

FIG. 2 shows a more detailed view of the wireless charger system with a resonant converter geometry, in accordance with an embodiment.

FIG. 3 illustrates a system wherein a dedicated RF channel for uni-directional or bi-directional communication between the charger and receiver is implemented for validation and/or regulation purposes, in accordance with an embodiment.

FIG. 4 illustrates the use a center-tapped receiver wherein during each cycle current passes only through one part of the coil and one diode in the receiver and therefore halves the rectification losses, in accordance with an embodiment.

FIG. 5 illustrates that the charger and receiver coils can be represented by their respective inductances by themselves and the mutual inductance between, in accordance with an embodiment.

FIG. 6 shows a wirelessly powered battery pack and receiver, in accordance with an embodiment.

FIG. 7 illustrates the use of a battery cell connected through a protection circuit comprising a battery protection

IC that protects a battery from over-current and under or over voltage, in accordance with an embodiment.

FIG. 8 illustrates a typical charge cycle for a Lithium Ion battery, in accordance with an embodiment.

FIG. 9 illustrates how the charger periodically activates the charger coil driver and powers the charger coil with a drive signal of appropriate frequency, in accordance with an embodiment.

FIG. 10 illustrates an example of the communication process and regulation of power and/or other functions, in accordance with an embodiment.

FIG. 11 shows a Notebook-style portfolio case and a mobile phone or camera pouch, where magnets are used to secure a closing clasp or flap, in accordance with an embodiment.

FIG. 12 illustrates several commercially available mounts for devices, in accordance with an embodiment.

FIG. 13 shows an example of a power plug for an electronic device, in accordance with an embodiment.

FIG. 14 shows an inductive wireless charger and/or power supply with multiple charging stations, in accordance with an embodiment.

FIG. 15 illustrates several different placements and shapes for magnets, in accordance with an embodiment.

FIG. 16 shows a measured z-component along the axial direction of magnetization of a magnet, in accordance with an embodiment.

FIG. 17 illustrates the performance of a $50 \times 50 \times 1 \text{ mm}^3$ magnet with one of $10 \times 10 \times 1 \text{ mm}^3$ dimension magnetized axially perpendicular to the square surface of the part, in accordance with an embodiment.

FIG. 18 illustrates how the same shape part can be periodically poled in a multi-pole pattern, in accordance with an embodiment.

FIG. 19 shows the drop off of maximum flux density value for a $10 \times 10 \times 1 \text{ mm}^3$ magnet magnetized periodically with a periodicity of 1 and 2 mm, in accordance with an embodiment.

FIG. 20 shows several magnet types that are magnetized perpendicular to the magnet surface (axially), in accordance with various embodiments.

FIG. 21 shows an example of various ring or arc multi-pole magnets, as may be used to with a coil to provide alignment, in accordance with an embodiment.

FIG. 22 illustrates a ring magnet that includes a discontinuity, in accordance with an embodiment.

FIG. 23 illustrates a multi-pole ring magnet with radially magnetized sections, in accordance with an embodiment.

DETAILED DESCRIPTION

With the proliferation of electrical and electronic devices and vehicles (which are considered devices herein), simple and universal methods of providing power and or charging of these devices is becoming increasingly important. To enable a user to easily charge or power these devices, a simple non-contact method such as wireless power transfer is increasingly important.

Many of these devices contain internal batteries, and the device may or may not be operating during receipt of power. Depending on the degree of charge status of the battery or its presence and the system design, the applied power may provide power to the device, charge its battery or a combination of the above. The terms charging and/or power are used interchangeably herein to indicate that the received

power can be used for either of these cases or a combination thereof. Unless specifically described, these terms are therefore used interchangeably.

As shown in FIG. 1, a wireless charger or power system comprises a charger or transmitter part, and a receiver part. The charger or transmitter can generate a repetitive power signal pattern (such as a sinusoid or square wave from 10^3 's of Hz to several MHz or even higher but typically in the 100 kHz to several MHz range) with its coil drive circuit and a coil or antenna for transmission of the power. The charger or transmitter typically also includes a communication and regulation/control system that detects a receiver and/or turns the applied power on or off and/or modify the amount of applied power by mechanisms such as changing the amplitude, frequency or duty cycle, etc. or a combination thereof of the applied power signal to the coil or antenna.

The second part of the system is a receiver that includes a coil or antenna to receive power, a method for change of the received AC voltage to DC voltage such as rectification and smoothing with one or more rectifiers or a bridge or synchronous rectifier, etc. and one or more capacitors and optionally, a method for the receiver to communicate with the charger.

In accordance with an embodiment, the method of communication between the charger and receiver can be through the same coils as for transfer of power, through a separate coil, through an RF or optical link or combination thereof. In case of communication through the power transfer coil, one method for the communication is to modulate the load in the receiver to affect the voltage in the receiver coil and therefore create a modulation in the charger coil parameters that can be detected through monitoring of its voltage or current. Other methods can include frequency modulation by combining the received frequency with a local oscillator signal or inductive, capacitive, or resistive modulation of the output of the receiver coil.

In accordance with an embodiment, the communicated information can be the output voltage, current, device or battery status, validation ID for receiver, end of charge or various charge status information, receiver battery, device, or coil temperature, or user data.

In accordance with an embodiment, the data communicated can be any of the information detailed herein, or the difference between these values and the desired value or simple commands to increase or decrease power or simply one or more signals that would confirm presence of a receiver or a combination of the above. In addition, the receiver can include other elements such as a dc to dc converter or regulator such as a switching, buck, boost, buck/boost, or linear regulator. The receiver may also include a switch between the DC output of the receiver coil and its output to a device or battery or a device case or skin and in cases where the receiver is used to charge a battery, the receiver may also include a battery charger IC or circuitry and/or battery protection circuit and associated transistors, etc. The receiver and/or charger and/or their coils can also include elements such as thermistors, magnetic shields or magnetic cores, magnetic sensors, and input voltage filters, etc. for safety and/or emission compliance reasons. In addition, the charger and or receiver can include means to provide more precise alignment between the charger and receiver coils or antennas. These may include visual, physical, or magnetic means to assist the user in alignment of parts. To implement more positioning freedom of the receiver on the charger, the size of the coils can also be mismatched. For example, the charger can comprise a

larger coil size and the receiver a smaller one or vice versa, so that the coils do not have to be precisely aligned for power transfer.

In accordance with an embodiment, the power section (coil drive circuit and receiver power section) can be a resonant, zero switching, flyback, or any other appropriate topology. FIG. 2 shows a more detailed view of the wireless charger system with a resonant converter geometry where a pair of transistors Q1 and Q2 (such as FETs) are driven by a half-bridge driver IC and the voltage is applied to the coil L1 through one or more capacitors shown as C1. The receiver includes a coil and an optional capacitor (for added efficiency) shown as C2 that may be in series or in parallel with the receiver coil L2. The charger and/or receiver coils may also include magnetic material layers behind them to increase their inductance or to shield the magnetic field leakage to surrounding area.

In accordance with an embodiment, the charger also includes a circuit that measures the current through and/or voltage across the charger coil (in this case a current sensor is shown in the figure as an example). Various demodulation methods for detection of the communication signal on the charger current or voltage are available. This demodulation mechanism can be an AM or FM receiver (depending on whether amplitude or frequency modulation is employed in the receiver modulator) similar to a radio receiver tuned to the frequency of the communication or a heterodyne detector, etc.

In accordance with an embodiment, the microcontroller unit (MCU) in the charger (MCU1) is responsible for understanding the communication signal from the detection/demodulation circuit and, depending on the algorithm used, making appropriate adjustments to the charger coil drive circuitry to achieve the desired output voltage, current or power from the receiver output. In addition, MCU1 is responsible for processes such as periodic start of the charger to seek a receiver at the start of charge, keeping the charger on when a receiver is found and accepted as a valid receiver, continuing to apply power and making necessary adjustments, and/or monitoring temperature or other environmental factors, providing audio or visual indications to the user on the status of charging or power process, etc. or terminating charging or application of power due to end of charge or customer preference or over temperature, over current, over voltage, or some other fault condition or to launch or start another program or process. For example, the charger can be built into a car and once a valid receiver integrated into or on a mobile device, its case or skin, or battery is found, the charger may activate some other functions such as Bluetooth connectivity to the device, displaying the device identity on a display, etc. Other similar actions can be done in other environments. It may be useful in addition to the communication signal to detect the dc value of the current through the charger coil. For example, faults may be caused by insertion or presence of foreign objects such as metallic materials between the charger and receiver. These materials may be heated by the application of the power and can be detected through detection of the charger current or temperature or comparison of input voltage, current, or power to the charger and output voltage, current, or power from the receiver and concluding that the ratio is out of normal range and extra power loss due to unknown reasons is occurring. In these conditions or other situations such as abnormal charger and/or receiver heating, the charger may be programmed to declare a fault condition and shut down and/or alert the user or take other actions.

Once the charger MCU has received a signal and decoded this signal, it can take action to provide more or less power to the charger coil. This can be accomplished through known methods of adjusting the frequency, duty cycle or input voltage to the charger coil or a combination of these approaches. Depending on the system and the circuit used, the MCU can directly adjust the bridge driver or an additional circuit such as a frequency oscillator may be necessary to drive the bridge driver or the FETs.

A typical circuit for the receiver in accordance with an embodiment, is also shown in FIG. 2. In accordance with an embodiment, the receiver circuit can include a capacitor C2 in parallel or series with the receiver coil to produce a tuned receiver circuit. This circuit is known to increase the efficiency of a wireless power system. The rectified and smoothed (through a bridge rectifier and capacitors) output of the receiver coil and optional capacitor is either directly or through a switch or regulator applied to the output. A microcontroller is used to measure various values such as output voltage, current, temperature, state of charge, battery full status, end of charge, etc. and to report back to the charger to provide a closed loop system with the charger as described above. In the circuit shown in FIG. 2, the receiver MCU communicates back to the charger by modulating the receiver load by rapidly closing and opening a switch in series with a modulation load at a pre-determined speed and coding pattern. This rapid load modulation technique at a frequency distinct from the power transfer frequency can be easily detected by the charger. A capacitor and/or inductor can also be placed in parallel or in series with this load.

For example, one may assume that the maximum current output of the receiver is 1000 mA and the output voltage is 5 V for a maximum output of 5 W. In this case, the minimum load resistance is 5 ohms. A modulation load resistor of several ohms (20, or 10 ohms or smaller) would be able to provide a large modulation depth signal on the receiver coil voltage. Choosing a 5 ohm resistor would modulate the output between a maximum current of 1 Amp or larger and a smaller value defined by the device load at the output. Such a large modulation can be easily detected at the charger coil current or voltage as described above.

The receiver in FIG. 2 also shows an optional dc regulator that is used to provide constant stable voltage to the receiver MCU. This voltage supply may be necessary to avoid drop out of the receiver MCU during startup conditions where the power is varying largely or during changes in output current and also to enable the MCU to have a stable voltage reference source so it can measure the output voltage accurately.

In the above description, a uni-directional communication (from the receiver to the charger) is described. However, this communication can also be bi-directional and data can be transferred from the charger to the receiver through modulation of the voltage or current in the charger coil and read back by the microcontroller in the receiver detecting a change in the voltage or current, etc.

In accordance with an embodiment, in other geometries where position independence on placement of the receiver on the charger surface is achieved by having multiple charger coils in an array or pattern, similar drive and communication circuits in the charger and receiver can be implemented. However, to detect the appropriate coil to activate in the charger, the coils can be activated in a raster or zigzag fashion or other geometry and current drawn from a charger coil, strength of voltage, current, power or signal from the receiver or other methods can be used to determine the closest match between position of one or more of the

charger coils and a receiver coil and the appropriate charger coil or coils can be activated and modulated to provide optimum power transfer to the receiver.

While a system for communication between the charger and receiver through the power transfer coil or antenna is described above, the communication can also be implemented through a separate coil, a radio frequency link (am or fm or other communication method), an optical communication system or a combination of the above. The communication in any of these methods can also be bi-directional rather than uni-directional as described above. As an example, FIG. 3 shows a system in accordance with an embodiment, wherein a dedicated RF channel for uni-directional or bi-directional communication between the charger and receiver is implemented for validation and/or regulation purposes. This system is similar to the system shown in FIG. 2, except rather than load modulation being the method of communication, the MCU in the receiver transmits the necessary information over an RF communication path. A similar system with LED or laser transceivers or detectors and light sources can be implemented. Advantages of such system may be that the power received is not modulated and therefore not wasted during communication and/or that no noise due to the modulation is added to the system.

One of the disadvantages of the circuit shown in FIG. 2 is that in the receiver circuit shown therein, the current path passes through 2 diodes and suffers 2 voltage drops resulting in large power dissipation and loss. For example, for Schottky diodes with forward voltage drop of 0.4 V, at a current output of 1 A, each diode would lose 0.4 W of power for a combined power loss of 0.8 W for the two in a bridge rectifier configuration. For a 5 V, 1 A output power (5 W), this 0.8 W of power loss presents a significant amount of loss (16%) just due to the rectification system. In accordance with an embodiment, an alternative is to use a center-tapped receiver as shown in FIG. 4 wherein during each cycle current passes only through one part of the coil and one diode in the receiver and therefore halves the rectification losses. Such a center tapped coil can be implemented in a wound wire geometry with 2 sections of a wound wire or a printed circuit board coil or with a double or multi-sided PCB coil or a combination or even a stamped, etched or otherwise manufactured coil or winding.

In any of the systems described above, as shown in FIG. 5, the charger and receiver coils can be represented by their respective inductances by themselves (L1 and L2) and the mutual inductance between them M which is dependent on the material between the 2 coils and their position with respect to each other in x, y, and z dimensions. The coupling coefficient between the coils k is given by:

$$k=M/(L1*L2)^{1/2}$$

The coupling coefficient is a measure of how closely the 2 coils are coupled and may range from 0 (no coupling) to 1 (very tight coupling). In coils with small overlap, large gap between coils or dissimilar coils (in size, number of turns, coil winding or pattern overlap, etc.), this value can be smaller than 1.

FIG. 6 shows a wirelessly powered battery pack and receiver in accordance with an embodiment. The components of a typical common battery pack (battery cell and protection circuit, etc.) used in a battery device used in applications such as mobile phone, etc. are shown inside the dashed lines. The components outside the dashed lines are additional components necessary to enable safe wireless and wired charging of a battery pack. A battery pack may have

four or more external connector points that interface with a mobile device pins in a battery housing or with an external typical wired charger. In accordance with an embodiment, the battery cell is connected as shown in FIG. 7 to two of these connectors (shown in the figure as Batt+ and Batt-) through a protection circuit comprising a battery protection IC that protects a battery from over-current and under or over voltage. A typical IC may be Seiko 8241 IC that uses 2 external FETs as shown in FIG. 7 to prevent current going from or to the battery cell (on the left) from the external battery pack connectors if a fault condition based on over current, or battery cell over or under voltage is detected. This provides safety during charging or discharging of the battery. In addition, a battery pack may include a PTC conductive polymer passive fuse. These devices can sense and shut off current by heating a layer inside the PTC if the amount of current passing exceeds a threshold. The PTC device is reset once this current falls and the device cools.

In addition, in accordance with an embodiment, the battery pack can contain a thermistor that the mobile device checks through one other connector on the battery pack to monitor the health of the pack, and in some embodiments an ID chip or microcontroller that the mobile device interrogates through another connector to confirm an original battery manufacturer or other information about the battery. Other connectors and functions can be included in a battery pack to provide accurate battery status and/or charging information to a device being powered by a battery pack or a charger charging the battery pack.

In addition to the components described above, In accordance with an embodiment, the receiver circuit comprises a receiver coil that could be a wound wire or PCB coil as described above, optional electromagnetic shielding between the coil and the metal body of the battery, optional alignment assisting parts such as magnets, etc., a receiver communication circuit (such as the resistor and FET for load modulation shown in FIGS. 2 and 4), a wireless power receiver (such as rectifiers and capacitors as discussed above), and an optional Battery charger IC that has a pre-programmed battery charging algorithm. Each type of battery and chemistry requires a pre-determined optimized profile for charging of a battery. A typical charge cycle for a Lithium Ion (Li-Ion) is shown in FIG. 8. Such a battery may be charged up to a value of 4.2 V at full capacity. The battery should be charged according to the guidelines of the manufacturer. For a battery of capacity C, the cell can typically be charged at the rate 1C. In Stage 1, the maximum available current is applied and the cell voltage increases until the cell voltage reaches the final value (4.2 V). In that case, the charger IC switches to Stage 2 where the charger IC switches to Constant Voltage charging where the cell voltage does not change but current is drawn from the source to further fill up the battery. This second Stage may take 1 or more hours and is necessary to fully charge the battery. Eventually, the battery will draw little (below a threshold) or no current. At this stage, the battery is full and the charger may discontinue charging. The charger IC can periodically seek the condition of the battery and top it off further if the battery has drained due to stand-by, etc.

Such multiple stages of battery charging may be implemented in firmware with the wireless power charger and receiver microcontrollers monitoring the battery cell voltage, current, etc. and working in tandem and to provide appropriate voltage, current, etc. for safe charging for any type of battery. In another approach as shown in FIG. 6, a battery charger IC chip that has specialized battery charging circuitry and algorithm for a particular type of battery can be

employed. These charger ICs (with or without fuel gauge capability to accurately measure battery status, etc.) are available for different battery chemistries and are included in most mobile devices with mobile batteries such as mobile phones. They can include such safety features as a temperature sensor, open circuit shut off, etc. and can provide other circuits or microcontrollers such useful information as end of charge signal, signaling for being in constant current or voltage (stage 1 or 2 above, etc.). In addition, some of these ICs allow the user to program and set the maximum output current to the battery cell with an external resistor across 2 pins of the IC.

In accordance with an embodiment, the wirelessly charged battery pack in addition includes a micro-controller that coordinates and monitors various points and may also include thermal sensors on the wireless power coil, battery cell and/or other points in the battery pack. The micro-controller also may communicate to the charger and can also monitor communication from the charger (in case of bi-directional communication). Typical communication through load modulation is described above.

Another aspect of a wirelessly charged battery pack is the optional external/internal switch. A battery pack may receive power and be charged wirelessly or through the connectors of a battery pack. For example when such a battery pack is used in a mobile phone, the user may wish to place the phone on a wireless charger or plug the device in to a wired charger for charging or charge the device as well as synchronize or upload and/or download information. In the second case, it may be important for the battery pack to recognize current incoming to the battery pack and to take some sort of action. This action may include notifying the user, shutting off the wired charger by a switch or simply shutting down the charger IC and sending a signal back through the micro-controller and modulating the current back to the charger that a wired charger is present (in case priority is to be given to the wired charger) or conversely to provide priority to the wireless charger and shut off wired charger access to battery when the wireless charger is charging the battery. At either case, a protocol for dealing with presence of two chargers simultaneously should be pre-established and implemented in hardware and firmware.

As shown in FIG. 6, the wireless charging of battery occurs with current flowing into the battery through the battery contacts from the mobile device. Typically, such current is provided by an external DC supply to the mobile device (such as an AC/DC adaptor for a mobile phone) and the actual charging is handled by a charger IC chip or power management IC inside the mobile device that in addition to charging the battery, measures the battery's state of charge, health, verifies battery authenticity, and displays charge status through LEDs, display, etc. to a user. It may therefore be advantageous to include a current sense circuit at one of the battery pack contacts to measure and sense the direction of current flow into or out of the battery. In case the current is flowing in (i.e. battery being externally charged through wired charging through a mobile device), the micro-controller may take the actions described above and shut off wireless charging or conversely, provide priority to wireless charging and if it is present, not allow wired charging to occur as preferred by design.

In accordance with an embodiment, the firmware in the receiver micro-controller is a key element in the operation of this battery pack. The micro-controller can measure voltages and currents, flags, and temperatures at appropriate locations for proper operation. In accordance with one embodiment, by way of example, the micro-controller can measure the

value of V_{out} from the rectifier circuit and attempt to keep this constant throughout the charging cycle thereby providing a stable regulated DC supply to the charger IC chip. The microcontroller can send back the value of this voltage or error from a desired voltage (for example 5V) or simply a code for more or less power back to the charger in a binary or multi-level coding scheme through a load modulation or other scheme (for example RF communication as described earlier) back to the charger. The charger can then take action through adjustment of input voltage to the charger coil, adjustment of the frequency or duty cycle of the ac voltage applied to the charger coil to bring the V_{out} to within required voltage range. The micro-controller throughout the charging process, in addition, monitors the end of charge and/or other signals from charger and/or protection circuit and the current sense circuit (used to sense battery pack current direction and value) to take appropriate action. Li-ion batteries for example need to be charged below a certain temperature for safety reasons. It is therefore essential to monitor the cell, wireless power receiver coil or other temperature and take appropriate action such as terminate charging or lower charging current, etc. if a certain maximum temperature is exceeded.

It is important to realize that during charging, as shown in FIG. 8, the battery cell voltage increases from 3 V or lower, to 4.2 V, as it is charged. The V_{out} of the wireless power receiver is input to a charger IC and if this V_{out} is kept constant (for example 5V), a large voltage drop (up to 2 V or more) can occur across this chip especially during Stage 1 where maximum current is applied. With charging currents of up to 1 A, this may translate to up to 2 Watts of wasted power/heat across this IC that may contribute to battery heating. It may be therefore preferable to implement a strategy whereby the V_{out} into the charger IC tracks the battery voltage thereby creating a smaller voltage drop and therefore loss across the charger IC. This can provide a significant improvement in performance since thermal performance of the battery pack is very important.

The communication between the receiver and charger needs to follow a pre-determined protocol, baud rate, modulation depth, etc. and a pre-determined method for handshake, establishment of communication, and signaling, etc. as well as optionally methods for providing closed loop control and regulation of power, voltage, etc. in the receiver.

In accordance with an embodiment, a typical wireless power system operation can be as follows: As shown in FIG. 9, the charger periodically activates the charger coil driver and powers the charger coil with a drive signal of appropriate frequency. During this 'ping' process, if a receiver coil is placed on top or close to the charger coil, power is received through the receiver coil and the receiver circuit is energized. The receiver microcontroller is activated by the received power and begins to perform an initiation process whereby the receiver ID, its presence, power or voltage requirements, receiver or battery temperature or state of charge and/or other information is sent back to the charger. If this information is verified and found to be valid, then the charger proceeds to provide continuous power to the receiver. The receiver may alternately send an end of charge, over-temperature, battery full, or other messages that will be handled appropriately by the charger and actions performed. The length of the ping process should be planned to be of sufficient length for the receiver to power up its microcontroller and to respond back and for the response to be received and understood. The length of time between the pings is determined by the designer. If ping process is performed often, the stand-by power use of the charger is

higher. Alternately, if the ping is done infrequently, the system will have a delay before the charger discovers a receiver nearby.

Alternately, the ping operation can be initiated upon discovery of a nearby receiver by other means. This provides a very low stand-by power use by the charger and may be performed by including a magnet in the receiver and a magnet sensor in the charger or through optical, capacitive, weight or other methods for detection. Alternatively, the system can be designed to be always ON (i.e. the charger coil is powered at an appropriate drive frequency) and presence of the receiver coil brings the coil to resonance with the receiver coil and power transfer occurs. The receiver in this case may not even contain a microcontroller and act autonomously and simply have a regulator to provide regulated output power to a device, its skin or case, or battery.

In accordance with an embodiment, the protocol for communication can be any of, e.g. common RZ, NRZ, Manchester code, etc. used for communication. An example of the communication process and regulation of power and/or other functions is shown in FIG. 10. As discussed above, the charger may periodically start and apply a ping voltage of pre-determined frequency and length to the charger coil (bottom figure in FIG. 10). The receiver is then activated and may begin to send back communication signals as shown in top of FIG. 10. The communication signal can include an optional preamble that is used to synchronize the detection circuit in the charger and prepare it for detection of communication. A communication containing a data packet may then follow, optionally followed by checksum and parity bits, etc. These processes are quite standard in communication systems and similar techniques can be followed. The actual data packet can include information such as an ID code for the receiver, received voltage, power, or current values, status of the battery, amount of power in the battery, battery or circuit temperature, end of charge or battery full signals, presence of external wired charger, or a number of the above. Also this packet may include the actual voltage, power, current, etc. value or the difference between the actual value and the desired value or some encoded value that will be useful for the charger to determine how best to regulate the output.

Alternatively, the communication signal can be a pre-determined pattern that is repetitive and simply lets the charger know that a receiver is present and/or that the receiver is a valid device within the power range of the charger, etc. Any combination of systems can be designed to provide the required performance.

In response to the receiver providing information regarding output power or voltage, etc. the charger may modify voltage, frequency, duty cycle of the charger coil signal or a combination of the above. The charger can also use other techniques to modify the power out of the charger coil and to adjust the received power. Alternatively the charger can simply continue to provide power to the receiver if an approved receiver is detected and continues to be present. The charger may also monitor the current into the charger coil and/or its temperature to ensure that no extra-ordinary fault conditions exist. One example of this type of fault may be if instead of a receiver, a metal object is placed on the charger.

The charger can adjust a parameter to increase or decrease the power or voltage in the receiver and then wait for the receiver to provide further information before changing a parameter again or it can use more sophisticated Proportional Integral Derivative (PID) or other control mechanisms

for closing the loop with the receiver and achieving output power control. Alternatively, as described above, the charger can provide a constant output power, and the receiver can regulate the power through a regulator or a charger IC or a combination of these to provide the required power to a device or battery.

Various manufacturers may use different coding and also bit rates and protocol. The control process used by different manufacturers may also differ, further causing interoperability problems between various chargers and receivers. A source of interoperability differences may be the size, shape, and number of turns used for the power transfer coils. Furthermore, depending on the input voltage used, the design of a wireless power system may step up or down the voltage in the receiver depending on the voltage required by a device by having appropriate number of turns in the charger and receiver coils. However, a receiver from one manufacturer may then not be able to operate on another manufacturer charger due to these differences in designs employed. It is therefore extremely beneficial to provide a system that can operate with different receivers or chargers and can be universal.

In accordance with an embodiment, to be able to detect and power/charge various receivers, the charger can be designed such that the initial Ping signal is at such a frequency range to initially be able to power and activate the receiver circuitry in any receiver during the ping process. After this initial power up of the receiver, the charger communication circuit should be able to detect and understand the communication signal from the receiver. Many microcontrollers are able to communicate in multiple formats and may have different input pins that can be configured differently to simultaneously receive the communication signal and synchronize and understand the communication at different baud rates and protocols. The charger firmware can then decide on what type of receiver is present and proceed to regulate or implement what is required (end of charge, shut-off, fault condition, etc.). Depending on the message received, then the charger can decide to change the charger driver voltage amplitude, frequency, or duty cycle or a combination of these to provide the appropriate regulated output.

In accordance with an embodiment, the charger's behavior can also take into account the difference in the coil geometry, turns ratio, etc. For example, a charger and receiver pair from one or more manufacturers may require operation of the charger drive voltage at 150 kHz. However, if the same receiver is placed on a charger from another manufacturer or driven with different coil/input voltage combination, to achieve the same output power, the charger frequency may need to be 200 kHz. The charger program may detect the type of receiver placed on it and shift the frequency appropriately to achieve a baseline output power and continue regulating from there.

As shown in FIG. 10, after the receiver sends back a communication signal back to the charger, in response to it, the charger adjusts its frequency and then awaits further information from the receiver. The receiver acknowledges the change and as shown in the second data packet in the receiver signal, has modified its state and communicates back to the charger. This closed loop continues during the charging process.

For receivers that contain an onboard regulator for the output power, the input voltage to the regulator is not as critical since the regulator performs a smoothing function and keeps the output voltage at the desired level with any load changes. It is however, important not to exceed the

maximum rated input voltage of the regulator or to drop below a level required so that the output voltage could no longer be maintained at the required value. However, in general, inclusion of a regulator and/or a charger IC chip (for batteries) reduces the power/voltage regulation requirements at the expense of the additional size and cost of this component.

While the system above describes a system where the communication is primarily through the coil, as described earlier, communication may be implemented through a separate coil, RF, optical system or a combination of the above. In such circumstances, a multi-protocol system can also be used to interoperate between systems with different communication and/or control protocols or even means of communication.

Alternately, the receiver may be designed to accommodate different types of chargers. For example, once a receiver is awakened by a charger, it may try to detect the ping frequency used by the charger. This may be done by any number of phase locking or other techniques. Alternately, the receiver may send back a variety of trial communication signals during ping process to establish which type of device is performing the ping. Once the type of the charger is established, the receiver can proceed and communicate with the appropriate communication protocol and frequency with the charger.

The multi-protocol approach described above is important for development of a universal system that can operate amongst multiple systems and provide user convenience.

The description for the systems above may use discreet electronics components or some or all of the functions described above may be integrated into an Application Specific Integrated Circuit (ASIC) to achieve smaller footprint, better performance/noise, etc. and/or cost advantages. Such integration is common in the Electronics industry and can provide additional advantages here.

Magnets for Use with Magnetically Sensitive Devices and Materials

Magnetically sensitive devices, materials, or components are used in a variety of applications in industrial, consumer, credit, debit, Identification, or loyalty cards, computer, MP3 players, cameras, medical, satellite, marine, mining, transport, and military applications. Examples of magnetically sensitive components or sensors include traditional or electronic compasses, Hall sensors, magnetometers, disk drives, speakers, rotational or linear encoders, pneumatic sensors, electric motor position sensors, etc. These sensors monitor and/or measure slight amounts of magnetic field. For example, a traditional or electronic compass (consisting of magnetometer or Hall Effect sensors) responds to the small magnetic field of the earth to provide directional information to the user. Use of a magnet near such a device would alter its performance and reliability. However, there are instances where such a use would be beneficial. As an example, recently, there is interest in incorporation of electronic compasses in mobile devices such as phones, GPS, cameras, electronic tablets, and electronic compasses to provide the user a portable navigation capability. Simultaneously, these devices have often used magnets to secure the device in a holder, case, or holster or to attach the device to a surface such as a holder in a car. One example of use of magnets in mobile phones is in certain phones, such as Blackberry-type phones, where the presence of a device in its holster containing a small magnet is detected by a magnetic sensor in a phone and activates certain actions that may be selectable

by the user on the phone. These actions can for example consist of turning the ringer on the phone off or switching to a vibrate mode.

In cases such as the phone described above, if a magnetic compass is implemented in the phone, the presence of a magnet in a case can interfere with the operation of the compass and/or navigation capabilities of the device. Another example is the often used magnetic discs or clasps in cases or holders for phones or cameras to close a protective cover on a mobile device, phone, computer, GPS device, etc. In these and many other cases, it is desired to have an easy method of fastening two parts together magnetically while not affecting the operation of the device or system.

FIG. 11 shows a Notebook-style portfolio case (left) and a mobile phone or camera pouch (right), where magnets are used to secure a closing clasp or flap. Magnets have also been used to secure cases or portfolios to Notebook computers or the back of their screens. These devices often incorporate components such as disk drives or magnetically sensitive components such as compasses, etc. that may be affected by use of such magnets. In addition, the existing magnetic sensors in the device (as in the blackberry phone case discussed above) may be affected by such magnets.

In addition, in many instances, it is desirable to hold or mount various devices securely by use of magnets. These can include having a convenient method for mounting of mobile phones, MP3 players, cameras, radar detectors, GPS units, compass, video screens, TVs, etc. in cars, boats, ships, trains, planes, helicopters, or other transport vehicles or work or home areas. Several commercially available mounts for such devices are shown in FIG. 12. In these instances, a magnetic or ferromagnetic base unit is coupled with a magnetic or ferromagnetic matching thin sticker or small sheet that can be attached or inserted inside a mobile device or its battery compartment or incorporated into a skin or case for the device such that the device will be attracted to the base and be held firmly during use or for storage. One or the other or both the holder or the mount and the other part incorporated into or on a device can be magnetic, to provide the necessary attractive force for this operation. Similarly, if the device is sensitive to magnetic fields, such a magnet can interfere with its operation.

Another area of use of magnets is in design of handbags, bags, backpacks, wallets, money clasps, etc. where magnets are used as a convenient method of closing or fastening parts to close or shut parts together. Use of magnets in such instances where the user may place a magnetically sensitive device, phone, camera, MP3 player with disk drive, GPS unit, compass, or credit cards, etc. may cause problems. In particular, erasure of data in credit cards due to use of magnets in wallets or handbags can be a concern.

More recently, magnets have been used to provide easy and safe connectivity between power or data cables and mobile devices or Notebook computers. As shown in FIG. 13 and described, for example in U.S. Pat. Nos. 7,311,526 and 7,645,143, a power plug for an electronic device or Notebook computer or deep fryer using a magnetic method for fastening and attachment of the power cable and its plug to the matching connector in the Notebook and a deep fryer. The magnet or ferromagnet material in the part of the plug surrounding the 5 connectors shown is attracted to the matching part in the Notebook and automatically aligns and connects the connectors in the 2 parts. The magnetic element on one or both of the plug and the device connector or receptacle can be a magnet to provide the necessary attractive force. The advantages of this type of connector is that

in case a user accidentally trips over such a cable, it would easily pull the cable out of the Notebook computer or deep fryer without damage to either side and pulling the product off to the floor causing damage or injury. This is a considerable advantage over other types of connectors that are mated by force and insertion of one part into another and liable to break in case of such accidents or cause unnecessary damage or injury. However, similar to the situations described above, use of such types of magnets near devices that are sensitive to the magnetic field such as mobile phones with compasses or devices with magnetic sensors or hard drives near the connector is problematic and therefore similar connectors are not used in many devices that can take advantage of this technology.

Another area of use of magnets is in the area of wireless power. With the proliferation of mobile devices in recent years, the area of powering and charging these devices has attracted more attention. The vast majority of the electronic devices in use today are powered and/or charged through conduction of electricity through wires from a power supply or charger to the device. While this method has proven to be efficient for most stationary devices, recently, there has been an interest in providing wireless methods for powering or charging several mobile devices, batteries, or electronics devices. The advantages include the ability to eliminate a power/charger cord and the possibility of implementing a universal charger/power supply that is able to charge/power multiple devices one at a time or simultaneously. In addition, in many situations, eliminating the connectors for charging and/or power would improve device and/or battery reliability. The so called "wireless power" methods can also be generally divided into conductive and inductive methods. While the conductive methods use flow of current from a charger into the mobile devices and/or battery to provide power and therefore are not strictly speaking wireless, they offer geometries where a user can place a device on a pad or similar object and receive power through matching contacts on the back of a device and the pad without 'plugging in' the device. The inductive methods utilize coils or wires near the surface of a charger to create a magnetic field in the vicinity of the surface. A coil or wire in a receiver embedded into a device or battery that is in the vicinity of the surface can sense the magnetic field. Power from the charger can be transferred to the receiver without any wired connection through air or other media in between. The inductive method has several advantages over the conductive approach, such as:

Connectors that are a major failure point in electronics are eliminated.

Environmentally hermetic devices can be developed that are immune to moisture or liquids.

The receiver can be built directly on the battery so the battery can be charged through the outside shell of the device by induction. This enables changing the battery of any existing product after-market with a similar sized and shaped battery to enable inductive charging.

With a properly designed charger pad, the charging is independent of position and does not require placement of device in any particular location or orientation.

Methods based on an array of connectors (e.g. U.S. Pat. No. 6,913,477 B2) or strips of power (e.g. www.pureenergy.com) in a pad that can power mobile devices conductively have been proposed. Sakamoto (H. Sakamoto and K. Harada in PESC'93 Record, pp168-174, Spain, (1992)) has also shown the possibility of recharging a device through a transformer coil with a core where the sections of the transformer can be separated. S. Hui, et al., in Electronics

Letters, 34, pp. 1052-1054, (1998) and S. Tang, et al., Electronics Letters, 36, pp 943-944 (2000), describe the use of coreless printed circuit board transformers. Fernandez, et al., in Proc. APECOZ, 2002, pp. 339-345, have described the process of optimization of PCB coils for power transfer. The use of a resonance circuit is described in U.S. Publication No. 2009/0015075 and U.S. Publication No. 2009/0033564.

As described herein, powering or charging of a mobile or electronic device or battery can be used interchangeably. Many mobile devices incorporate rechargeable batteries and require external DC power to charge these batteries for operation. However, in case of some devices such as a notebook, computer, etc., while the device is connected to DC power to charge its internal battery, the device can also be using the DC power to operate simultaneously. The ratio of power used for charging the internal rechargeable battery to operating the device depends on the degree to which the battery is discharged, the power necessary to operate the device, and what the device is doing at any given time. In the extreme, a laptop with its battery removed can only use the DC power to operate. In this case no charging occurs and 100% of the provided DC power is used to operate the device.

In some of the applications described above, magnets can be used to provide alignment or a secure connection for an electrical contact. For example, in some implementations of the inductive charging technology, it may be desirable to provide alignment between the charger and receiver coils by aligning them through use of disk, ring, or other magnets attached to the two coils. When a receiver embedded in a device, battery, battery door, skin, or case is brought close to a charger surface, the corresponding magnets can attract and bring the coils to the necessary alignment for optimum power transfer. Several embodiments for implementing this, for example to provide higher insensitivity to placement of the receiver, better mechanical and smaller volume requirements, minimal impact on power transfer, etc., are described in U.S. patent applications "INDUCTIVE POWER SOURCE AND CHARGING SYSTEM", application Ser. No. 11/669,113, filed Jan. 30, 2007 (subsequently published as U.S. Publication No. 20070182367, and issued as U.S. Pat. No. 7,952,322); "POWER SOURCE, CHARGING SYSTEM, AND INDUCTIVE RECEIVER FOR MOBILE DEVICES", application Ser. No. 11/757,067, filed Jun. 1, 2007 (subsequently published as U.S. Publication No. 20070279002, and issued as U.S. Pat. No. 7,948,208); "SYSTEM AND METHOD FOR INDUCTIVE CHARGING OF PORTABLE DEVICES", application Ser. No. 12/116,876, filed May 7, 2008 (subsequently published as U.S. Publication No. 20090096413); and "SYSTEM AND METHODS FOR INDUCTIVE CHARGING, AND IMPROVEMENTS AND USES THEREOF"; application Ser. No. 12/769,586, filed Apr. 28, 2010 (subsequently published as U.S. Publication No. 20110050164), each of which applications are hereby incorporated by reference herein.

FIG. 14 shows an Inductive wireless charger and/or power supply with multiple charging stations in accordance with an embodiment. The inductive receiver can be incorporated into a mobile device, its battery door, case or skin, a battery, etc. To align the coil in the charger and the coil in the receiver, magnets that attract the coils into alignment can be incorporated or on around the coils. Many types of magnets such as round discs, square, ring, oval, rectangular, arc, etc. can be used for alignment of coils. In FIG. 14, round disc (top) and ring (bottom) magnets are used for this alignment. One or many magnets can be used. Several different place-

ments and shapes for magnets are shown in FIG. 15 by way of example. For example, a single disc or square, or other shaped magnet at the center of each coil can be used. In other implementations, 4 disc or square magnets placed in the corners of a square pattern can be used or other patterns. The patterns shown herein are shown by way of example. In accordance with other embodiments, other numbers and/or shapes of magnets or magnetization direction or strength can be used to achieve the desired alignment. It is possible to incorporate magnets with attracting magnetic orientation in the two parts to be aligned or alternatively, only one or one set of magnets and a ferromagnetic or magnetically attractable material used in the other part to achieve similar alignment results.

The advantage of use of a single disc magnet in the center of a charger and one in the center of a receiver is that the receiver can rotate with respect to the charger and still maintain optimum alignment. With 4 magnets placed as shown in FIG. 15, the coils can be rotated 90, 180, or 270 degrees with respect to each other and still maintain alignment. Other shapes or number of magnets can be used and patterns in FIG. 15 are shown only as a way of example. The magnets can be magnetized with the magnet direction perpendicular to the face of the disk or magnet and by using magnet poles in the charger and receiver such that the pole is in the same direction in both, for example as south pole out of the page. When the two devices are close to each other, the magnets attract and align the coils. U.S. patent applications "INDUCTIVE POWER SOURCE AND CHARGING SYSTEM", application Ser. No. 11/669,113, filed Jan. 30, 2007 (subsequently published as U.S. Publication No. 20070182367, and issued as U.S. Pat. No. 7,952,322); "POWER SOURCE, CHARGING SYSTEM, AND INDUCTIVE RECEIVER FOR MOBILE DEVICES", application Ser. No. 11/757,067, filed Jun. 1, 2007 (subsequently published as U.S. Publication No. 20070279002, and issued as U.S. Pat. No. 7,948,208); "SYSTEM AND METHOD FOR INDUCTIVE CHARGING OF PORTABLE DEVICES", application Ser. No. 12/116,876, filed May 7, 2008 (subsequently published as U.S. Publication No. 20090096413); and "SYSTEM AND METHODS FOR INDUCTIVE CHARGING, AND IMPROVEMENTS AND USES THEREOF"; application Ser. No. 12/769,586, filed Apr. 28, 2010 (subsequently published as U.S. Publication No. 20110050164), each of which applications are hereby incorporated by reference herein, each of which applications are hereby incorporated by reference herein, previously described improvements on the design of alignment magnets. For example, in FIG. 15 or FIG. 16, disc, square, rectangular, or ring magnets are used in the charger and the receiver with the magnets magnetized in the direction perpendicular to the flat surface. A gap in the ring magnet is incorporated to reduce potential eddy currents due to changing magnetic field of the wireless charger/power supply. Ring magnets have better performance for these applications due to the larger diameter of the magnet that can be used in this case (thereby providing a larger alignment target for the user), the ability to rotate one coil with respect to the other one at any angle and maintain alignment, and the ability to reduce or eliminate any potential eddy currents through a cut in the ring as described above. In accordance with other embodiments, other shapes or combinations of shapes, such as square, rectangle, circle, oval, or triangle, etc. rings or other narrow wall, or others or combination of the above can be used depending on the particular needs of the intended application.

In some situations, the charger/and or power supply is incorporated into a mobile device or part that includes a magnetically sensitive portion. For example, the charger can be incorporated into a notebook or laptop or computer with a disk drive, compass, or other magnetically sensitive parts. In these instances, incorporation of the magnet or magnets in the charger as well as the receiver can pose problems for the device incorporating the charger as well as for the device or part incorporating the receiver.

In accordance with various embodiments, the coils described here can be manufactured with wires, Litz wire, Printed circuit board (PCB), stamped, formed, shaped, etc. metal or magnetic material. The spiral patterns shown here are for example only and the coils can be any shape or size or pattern that could generate a magnetic field.

Similarly, the alignment can be achieved between a magnet or magnets incorporated into or around one of the coils and a part constructed of ferromagnetic or other magnetic material that can be attracted to the magnet for alignment. The magnet or the magnetically attracted part can be made from Nickel, Iron, Cobalt, gadolinium and dysprosium, steel, etc. or an alloy of these materials or ceramic, Alnico, Ticonal, Rare Earth magnets, flexible or injection molded or nano-crystalline magnets so that the magnets on the receiver attract and attach to the magnetic or ferromagnetic material on the other part. Examples of metal or magnetic material or ferromagnetic material that could form the opposite side are Nickel, Steel, cobalt, gadolinium and dysprosium, steel, etc. or an alloy of these material or ceramic, Alnico, Ticonal, Rare Earth magnetic material, flexible or injection molded or nano-crystalline materials or any other material that can be attracted to a magnet or an alloy containing such. Of course, either the receiver or charger can incorporate a magnet and the other part a material that is attracted to a magnet or vice versa or both can contain magnets with poles arranged such that they attract each other for alignment. The type of materials discussed above or combination thereof can be used in any of these cases. The magnets can be permanent magnets or electromagnets activated by application of an electrical current.

Similarly, in conductive types of wireless or wire free charging or power, the connectors on a receiver in or on a device or skin, etc. are often magnetized to attract strips of metal or additional magnets on a pad to make a strong connection. For example, some companies produce a conductive type of so called "wireless" or "wire-free" charger. In some instances, connectors on the back of a mobile device incorporated into the device, its skin, or battery door, or an additional part attached to the back of the device contain a number of metallic contacts which make contact with metal strips on a pad. The metal strips are connected to a power supply rail with an applied voltage and upon contact with the receiver connectors and verification of the receiver, provide necessary voltage and/or current to the receiver. To enable a strong connection between the receiver and the pad metal strips or to enable the receiver and the device it is attached or incorporated in, to be placed at an angle or vertically, etc., the metal strips are made of a magnetic or ferromagnetic material such as Nickel, Iron, Cobalt, gadolinium and dysprosium, steel, etc. or an alloy so that the magnets on the receiver contact attract and attach to the strips. Enabling such an attractive contact is especially important when it is desired that the device not move during the charging process such as when the charger pad is used or incorporated into a car, airplane, ship, boat, etc. where motion is present. However, in instances where the mobile device contains a compass such as an electronic compass in certain phones,

use of magnets in the receiver connectors interferes with such an operation. Therefore the manufacturer has generally not incorporated magnetic connectors for such instances, which eliminates the benefits of the magnetic attachment.

In these and many other applications, it may be desirable to benefit from the seemingly contradictory use of magnets for their advantages in providing an attractive force for fastening, mounting, holding, or alignment, while at the same time it is desired to minimize or eliminate any effect on magnetically sensitive components in the charger or receiver or devices or parts nearby. This contradiction can be resolved by realizing that it is possible to create magnets with a net magnetic field that is zero or small in areas near or far from the magnet and at the same time that the part retains its magnetic or attractive properties at close distances and can provide attractive forces.

To achieve small overall net magnetic field, it is important to realize that the magnetic field is a vector and fields from several magnets or parts or poles of the same magnet add to provide the total sum of the field at any location in space.

Many magnets such as Rare Earth magnets are made using a sintering process whereby the basic material components such as Iron, Nickel, Cobalt, and/or Rare Earth material are refined and then combined in the desired composition and melted in a furnace to produce starting ingots for a magnet. The ingots are then ground and the resulting particles are placed in a jig or mold with the desired shape and dimensions and pressed into shape while an external magnetic field is applied to orient the particles. By applying the appropriate magnetic field in the desired direction, in plane, out of plane, radial, or multi-pole poling of the magnet can be achieved. For example, multi-pole magnets are created by pulse magnetization. To create a linear period multi-pole magnet, a magnetizing fixture with a back and forth copper wire arrangement is used. Application of a short current pulse from a capacitor through the fixture produces a magnetic field strong enough to magnetize material in the vicinity of the wire pattern. By controlling the shape and size of the induced magnetic field various magnet types can be created. The resulting part is then treated in a sintering furnace to compact the material before further testing of the parameters and coating of the final magnet to avoid corrosion. As an example, multi-pole magnets with periodicity of 1-2 mm in substrates of 2 mm thick or less have been studied for micro-actuator applications (J. Topfer, and V. Christoph, "Multi-pole Magnetization of NdFeB Sintered Magnets and Thick Films for Magnetic Micro-Actuators", *Sensors and Actuators, A* 113 (2004) 257-263 AND J. Töpfer, B. Pawlowski, H. Beer, K. Plötner, P. Hofmann, M. Herfurth, Multi-pole magnetization of NdFeB magnets for magnetic micro-actuators and its characterization with a magnetic field mapping device, *J. Magn. Mater.* 270 (2004) 124-129).

Töpfer, et al. manufactured NdFeB square magnets of $50 \times 50 \times 1$ mm³ dimension magnetized axially perpendicular to the square surface of the part and characterized it. FIG. 16 shows Measured z-component (along the axial direction of magnetization) of the magnetic flux density of this magnet measured by moving a Hall Sensor along the middle of one edge of the square to the opposite edge of the square 250 micrometers above the surface of the magnet as shown in the inset. The results show that in such a magnet, the field peaks at the edges and in the center, a strong demagnetization field exists that almost reduces the magnetic flux to zero at this center, thereby not providing much attractive or retention force for such thin magnets.

In FIG. 17, the same researchers compare the performance of a $50 \times 50 \times 1$ mm³ magnet with one of $10 \times 10 \times 1$ mm³ dimension magnetized axially perpendicular to the square surface of the part. The smaller magnet retains its magnetic flux to a greater degree at its center and has higher peaks at the edges. Also note that the peak of the magnetic flux is higher for this magnet.

To further retain high flux density in a magnet, the same shape part can be periodically poled in a multi-pole pattern as shown in FIG. 18. Here, the $10 \times 10 \times 1$ mm³ magnet is magnetized periodically with a periodicity of 2 mm as shown on the top FIG. 18. The bottom figure shows the measured magnetic flux density. It can be seen that flux density follows the poling pattern but in addition, comparing the magnitude of the flux density, it can be seen that the peak values are about twice the peak value of the flux density in a uniformly magnetized magnet. In addition, the magnetic flux does not show any sign of demagnetization and reduction of the peak values at the center of the magnet that is seen in FIGS. 16 and 17. Overall, multi-pole magnetization can provide a method for achieving higher and more uniform magnetic flux in a magnet. These characteristics are desirable for applications described here where retention and alignment of parts are required.

An important aspect of the performance of the multi-pole magnets described here is the performance of these magnets away from the surface of the magnets. FIG. 19 shows the drop off of maximum flux density value for a $10 \times 10 \times 1$ mm³ magnet magnetized periodically with a periodicity of 1 and 2 mm as shown on the top as a function of distance between the probe and the top of the magnet. It can be seen that the flux density drops off very quickly and reaches small values for over 1 mm. This is a result of the geometry shown on the top of the figure. With multiple poles present, as the distance between the probe and the magnet increases, the probe measures the sum of the flux density from the multiple poles present and this value approaches zero quickly away from the surface. At the same time, near the surface, the flux density is larger for the multi-pole magnet as compared to a single pole magnet, and increases as the pole periodicity increases (up to a limit given the physical dimensions of the magnet, its thickness, etc.). It is important to recall that the peak for a uniformly magnetized magnet of same dimension was only around 0.13 T (<1/3 of the 1 mm periodically poled similarly sized magnet value) as shown in FIGS. 18 and 19. At the same time, as discussed above, the uniformly magnetized magnet also showed a very significant reduction of the flux density at its center which is not present for the multi-pole magnet.

In summary, the results above demonstrate that properly designed multi-pole magnets can provide significantly higher and more uniform flux density near their surface while at the same time providing much lower flux densities away from the surface.

These characteristics can be used to provide the combination of characteristics that are useful for mounting, holding, attachment, and alignment purposes for the applications discussed earlier. By using multi-pole magnets higher retention and alignment force can be provided, while reducing the effect of any stray fields on nearby magnetically sensitive components, parts, or materials.

FIG. 20 shows several magnet types that are magnetized perpendicular to the magnet surface (axially), in accordance with various embodiments. For example, FIG. 20 shows (a) rectangular magnet magnetized in a checkerboard pattern, (b) square magnet magnetized in a checkerboard pattern, (c) rectangular magnet magnetized in a single direction multi-

pole pattern, (d) square magnet magnetized in a single direction multi-pole pattern, (e) disc magnet magnetized into 4 sections, (f) disc magnet magnetized into 8 sections, (g) ring magnet magnetized into 8 sections, and (h) disc magnet magnetized into concentric circular sections. These patterns are shown by way of illustration and it is obvious that many types of magnets and shapes can be devised for various applications with regular or irregular shapes that have multi-pole magnetic patterns.

For applications in securing or mounting of parts to another part, a multi-pole magnet similar to magnets in FIG. 20 or another appropriate shape and size and number of poles can be devised for the device to be mounted or the mount and combined with a matching magnet or ferromagnetic or other magnetically attractable material on the opposite part (device or mount) to provide attraction between the two parts. Since each magnet includes a number of poles, this approach allows both for central alignment between the two parts (i.e. their respective magnets or magnetically attractable material are centered with respect to one another); and stepped or rotational alignment between the two parts (i.e. their respective magnets or magnetically attractable material can be center-aligned with respect to one another, and then rotated around those centers in steps corresponding to the number of poles, wherein at each step the full magnetic attraction is provided). This allows for novel uses of such magnets, for example to allow parts to be attached to one another in a variety or particular number of relative orientations.

In accordance with an embodiment, in applications such as shown in FIG. 11-15, the appropriately designed magnet can be used instead of the uniformly magnetized magnets of earlier design, to provide stronger or similar attractive force while producing minimal or zero magnetic field away from the magnet not to disturb other magnetically sensitive parts or devices.

As an example, in accordance with various embodiments, ring or arc multi-pole magnets such as those shown in FIG. 21 can be used with the coil to provide alignment. It will be evident that improvements such as cuts or discontinuities, etc. for reduction of eddy currents can be implemented as in singly poled magnets described for example in U.S. patent applications "INDUCTIVE POWER SOURCE AND CHARGING SYSTEM", application Ser. No. 11/669,113, filed Jan. 30, 2007 (subsequently published as U.S. Publication No. 20070182367, and issued as U.S. Pat. No. 7,952,322); "POWER SOURCE, CHARGING SYSTEM, AND INDUCTIVE RECEIVER FOR MOBILE DEVICES", application Ser. No. 11/757,067, filed Jun. 1, 2007 (subsequently published as U.S. Publication No. 20070279002, and issued as U.S. Pat. No. 7,948,208); "SYSTEM AND METHOD FOR INDUCTIVE CHARGING OF PORTABLE DEVICES", application Ser. No. 12/116,876, filed May 7, 2008 (subsequently published as U.S. Publication No. 20090096413); and "SYSTEM AND METHODS FOR INDUCTIVE CHARGING, AND IMPROVEMENTS AND USES THEREOF"; application Ser. No. 12/769,586, filed Apr. 28, 2010 (subsequently published as U.S. Publication No. 20110050164), each of which applications are hereby incorporated by reference herein. For example, the ring magnet in FIG. 22 shows an implementation of such a discontinuity at the bottom of the figure.

While most of the description below is based on the inductive method of power transfer, the embodiments described here can be implemented with either the inductive method or the conductive method or the magnetic resonance

method, optical, or other methods for power transfer some of which have been described above. Inductive methods of power transfer are described above as an example of the more general wireless power transfer.

Furthermore, the type of magnets discussed above may be used with magnetic shielding material commonly in use for reduction of AC or DC magnetic field such as mumetal, etc. available from Magnetic Shield Corporation or material such as thin flexible sheets available from Maruwa or nano materials such as Finemet from Hitachi Corp or ferromagnetic or alloys of ferromagnetic materials such as iron, nickel and cobalt. For example in the case of the inductive charger or receiver described above, the area behind a coil can be covered by a magnetic shield material and a square, rectangle, ring or arc of multi-pole magnet can be attached around and/or on such a shield and be used for attraction and alignment of the charger and receiver coil to each other. FIG. 22 shows such an arrangement where multi-pole magnets (multi-pole ring (left) and arc (right) magnet on or around an inductive coil) and magnetic shielding material are used behind a coil. Here, the magnetic shield layer or material shields behind the coil provides shielding from the alternating magnetic field of the coil. An optional cut/discontinuity in the ring (shown at the bottom of the ring magnet on the left) prevents or reduces eddy currents during operation of the inductive coil.

In addition, heat transfer layers can be incorporated to spread the heat generated. Such layers need to be designed not to interfere with the operation of the coils. Since alternating magnetic fields are generated and detected in an inductive system, use of a metal layer behind the coil would produce eddy currents and loss. One method for providing thermal conductivity with metal layers is where a metal layer with discontinuous portions is placed behind and/or around the coil. In this case, the metal layer can comprise rectangular slices that can conduct heat away from the center of a coil while, due to discontinuity between the slices, the electrons can not flow in a circular motion due to the alternating magnetic field. The pattern described here has a number of triangular slices but any other pattern which can provide heat transport but does not allow carriers to circulate in a rotational pattern due to the alternating magnetic field can be implemented.

Alternatively, multi-pole magnets can be manufactured by way of taking a single poled magnet, cutting it into appropriate sections, and reassembling the pieces and attaching them together with an adhesive, glue, or other bonding agent or other material; or alternatively a holder, etc. or clamp or screws or external force or other methods, so that the multi-pole geometry is achieved. For example, a single poled axially poled (out of plane of ring) ring can be cut into 4, 8, 16, or another number of even or odd sections, and half of the sections turned over and reassembled to provide a multi-pole magnet. To aid in assembly of such a magnet, it may be necessary to attach or place the parts on to another solid continuous piece. This piece may be magnetic, ferromagnetic, or non-magnetic itself. For example, in the ring magnet example above, the pieces of the ring magnet can be attached and reassembled in a multi-pole geometry on a stainless steel, iron, Nickel, plastic, or copper, etc. ring to aid in assembly and to hold the sections together. The properties of the backing material, its thickness, etc. can also be optimized to provide necessary performance. For example, use of a ferromagnetic material as backing can further provide a path for the magnetic flux in that section and provide further tighter coupling between sections and reduction of magnetic field away from the ring. It may also be

desirable to sandwich the magnet on both sides with similar or dissimilar backing material or layers, or use multiple backing layers to further engineer symmetric or asymmetric properties on the two sides of the multi-pole magnet.

FIG. 23 shows a multi-pole ring magnet with radially magnetized sections. In use of the magnet for inductive charging applications, a cut or break in the circle or arc magnets as described earlier can be used.

While in the above description, emphasis has been given to affixing electronic parts, batteries, electric parts, etc to other parts or components or cases, holders, etc., the processes, systems, and methods described above can be similarly used to permanently or temporarily fix, attach, align, or establish relation between any two or more parts of the same or different items, products, areas, etc., including those not directly related to electronics. Examples include in lighting, furniture, automotive, mechanical instruments or machines, electronics, electrical systems and components, batteries, cases, purses, clothing, footwear, or any other number of applications. Other examples can be developed in accordance with other applications.

Some aspects of the present invention can be conveniently implemented using a conventional general purpose or a specialized digital computer, microprocessor, or electronic circuitry programmed according to the teachings of the present disclosure. Appropriate software coding can readily be prepared by skilled programmers and circuit designers based on the teachings of the present disclosure, as will be apparent to those skilled in the art.

In some embodiments, the present invention includes a computer program product which is a storage medium (media) having instructions stored thereon/in which can be used to program a computer to perform any of the processes of the present invention. The storage medium can include, but is not limited to, any type of disk including floppy disks, optical discs, DVD, CD-ROMs, microdrive, and magneto-optical disks, ROMs, RAMs, EPROMs, EEPROMs, DRAMs, VRAMs, flash memory devices, magnetic or optical cards, nanosystems (including molecular memory ICs), or any type of media or device suitable for storing instructions and/or data.

The foregoing description of the present invention has been provided for the purposes of illustration and description. It is not intended to be exhaustive or to limit the invention to the precise forms disclosed. Many modifications and variations will be apparent to the practitioner skilled in the art. The embodiments were chosen and described in order to best explain the principles of the invention and its practical application, thereby enabling others skilled in the art to understand the invention for various embodiments and with various modifications that are suited to the particular use contemplated. It is intended that the scope of the invention be defined by the following claims and their equivalence.

What is claimed is:

1. A universal system including a base unit for an intelligent inductive power transfer process, the system having a charger or power supply being capable of operating under a plurality of inductive power transfer protocols for communication and control of the inductive power transfer process such that each power transfer protocol allows wireless charging operation between receivers and the base unit, the receivers and the base unit being of different manufacturers but also being capable of adhering to an appropriate universal charging protocol chosen from inductive power transfer protocols that are not interoperable,

wherein the base unit and the receivers communicate unidirectionally or bi-directionally with each other prior to charging or powering to determine the appropriate universal charging protocol and then proceed to charge or power mobile devices via the receivers using the appropriate universal charging protocol;

wherein the appropriate universal charging protocol defines and establishes one or more of the power transfer frequencies of the charger, a communication method or communication encoding, or data rate and message structure or power requirement; and

wherein the system allows for interoperability of different communication protocols that are otherwise inoperable without the system.

2. The system of claim 1, wherein the base unit and mobile devices communicate with each other to verify the authenticity, power requirements and/or other characteristics of the mobile devices and/or verify or handshake the presence of the mobile devices proximate the base unit.

3. The system of claim 1, wherein the base unit and/or mobile devices include a microcontroller that determines the authenticity, power requirements and/or other characteristics of the mobile devices and determines the protocol to be used to charge or power the mobile devices.

4. The system of claim 1, wherein the base unit periodically powers its charger coil and checks for the presence of mobile devices in proximity to the base unit which receiver coil or receiver can receive power from the charger coil.

5. The system of claim 1, wherein the base unit periodically pings for the presence of mobile devices in proximity to the base unit, and wherein a receiver coil or receiver thereby activated performs an initiation process whereby its ID, presence, power, voltage or other requirements are communicated to the base unit.

6. The system of claim 1, wherein the base unit periodically pings for the presence of mobile devices in proximity to the base unit, and wherein the length of a ping is of sufficient length for a receiver to power up its microcontroller and to respond back, and for the response to be received and understood.

7. The system of claim 1, wherein the base unit pings for the presence of mobile devices only upon discovery of a nearby receiver coil or receiver.

8. The system of claim 1, wherein the base unit and/or mobile devices include a microcontroller that implements in firmware an algorithm for supporting multiple different charging protocols, for use with the mobile devices, and/or to communicate parameters to increase or decrease power or voltage provided to the receiver coil or receiver.

9. The system of claim 1, wherein the base unit and/or mobile devices include a microcontroller, and wherein the system supports different protocols to be used to charge or power the mobile devices, including wherein the microcontroller receives and decodes signals and in response takes action to provide more or less power to the charger coil, by adjusting the frequency, duty cycle and/or input voltage to the charger coil.

10. The system of claim 1, wherein the base unit is provided within an automobile, for use in charging or powering mobile devices within the automobile, and/or the mobile devices comprise the automobile that can be charged by a base unit.

11. A universal method of an intelligent inductive power transfer process, the method being capable of a plurality of inductive power transfer protocols for communication and control of the inductive power transfer process such that each power transfer protocol allows wireless charging

25

operation between receivers and the base unit, the receivers and the base unit being of different manufacturers but also being capable of adhering to an appropriate universal charging protocol chosen from inductive power transfer protocols that are not interoperable, the method comprising the steps of:

providing a receiver coil or receiver associated with a battery mobile device or provided as a separable or after-market accessory for use with the mobile device; wherein the base unit and the receivers communicate with each other unidirectionally or bi-directionally prior to charging or powering to determine the appropriate universal charging protocol and then proceed to charge or power mobile devices via the receivers using the appropriate universal charging protocol; and wherein the appropriate universal charging protocol defines and establishes one or more of the power transfer frequencies of the charger, a communication method or communication encoding, or data rate and message structure or power requirement; and wherein the method allows for interoperability of different communication protocols that are otherwise inoperable without the method.

12. The method of claim 11, wherein the base unit and mobile devices communicate with each other to verify the authenticity, power requirements and/or other characteristics of the mobile devices and/or verify or handshake the presence of the mobile devices proximate the base unit.

13. The method of claim 11, wherein the base unit and/or mobile devices include a microcontroller that determines the authenticity, power requirements and/or other characteristics of the mobile devices and determines the protocol to be used to charge or power the mobile devices.

14. The method of claim 11, wherein the base unit periodically powers its charger coil and checks for the presence of mobile devices in proximity to the base unit which receiver coil or receiver can receive power from the charger coil.

26

15. The method of claim 11, wherein the base unit periodically pings for the presence of mobile devices in proximity to the base unit, and wherein a receiver coil or receiver thereby activated performs an initiation process whereby its ID, presence, power, voltage or other requirements are communicated to the base unit.

16. The method of claim 11, wherein the base unit periodically pings for the presence of mobile devices in proximity to the base unit, and wherein the length of a ping is of sufficient length for a receiver to power up its microcontroller and to respond back, and for the response to be received and understood.

17. The method of claim 11, wherein the base unit pings for the presence of mobile devices only upon discovery of a nearby receiver coil or receiver.

18. The method of claim 11, wherein the base unit and/or mobile devices include a microcontroller that implements in firmware an algorithm for supporting multiple different charging protocols, for use with the mobile devices, and/or to communicate parameters to increase or decrease power or voltage provided to the receiver coil or receiver.

19. The method of claim 11, wherein the base unit and/or mobile devices include a microcontroller, and wherein the system supports different protocols to be used to charge or power the mobile devices, including wherein the microcontroller receives and decodes signals and in response takes action to provide more or less power to the charger coil, by adjusting the frequency, duty cycle and/or input voltage to the charger coil.

20. The method of claim 11, wherein the base unit is provided within an automobile, for use in charging or powering mobile devices within the automobile, and/or the mobile devices are automobiles that can be charged by a base unit.

* * * * *